

Megaswitch M

Our Megaswitch M is connected on both sides of the circuit board. On one side you will find the soldering lugs / connections A to L and on the other side the soldering lugs / connections M to X.

You can use Megaswitch M for the following switching positions:

SSS4

This is another version of the SSS2 and the SSS3. The connections and resultant sounds in positions 1, 2, 4 and 5 the same as usual. In position 3 however, the bridge and neck pickups are switched in series. This creates a fuller, softer sound than parallel switching. This configuration requires the Megaswitch M. It is advisable here to connect the two tone controls to the neck and bridge pickups. If a reduction in the high frequencies is required in position 3, both tone controls must be adjusted accordingly. When the magnetic orientation is S-N-S or N-S-N, positions 2 and 4 are buzz-free. If a buzz-free sound is required in position 3 however, this can be obtained by exchanging the neck and the middle pickups, which in turn results in a buzzing sound in position 2. A buzz-free sound can also be obtained in position 3 by exchanging the middle and bridge pickups, which makes position 4 buzz.

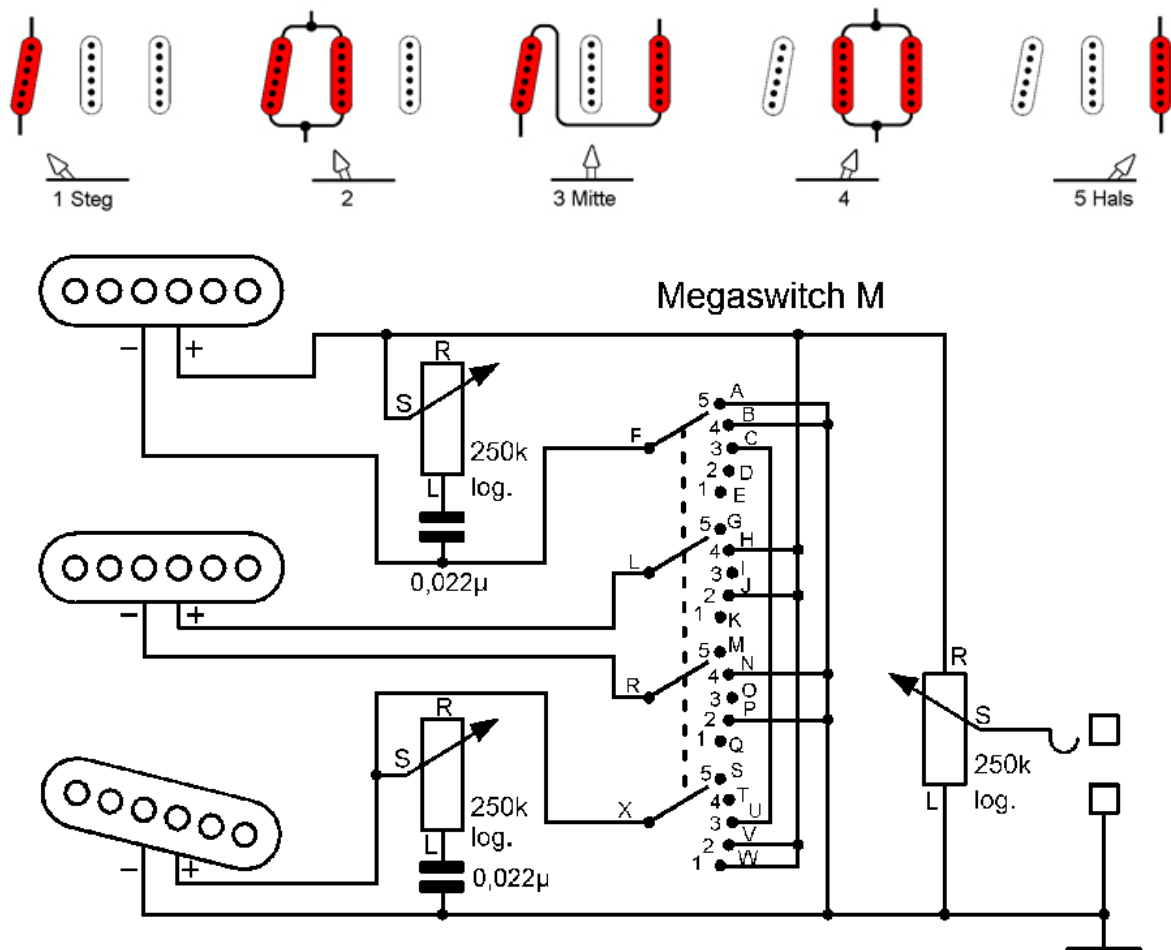

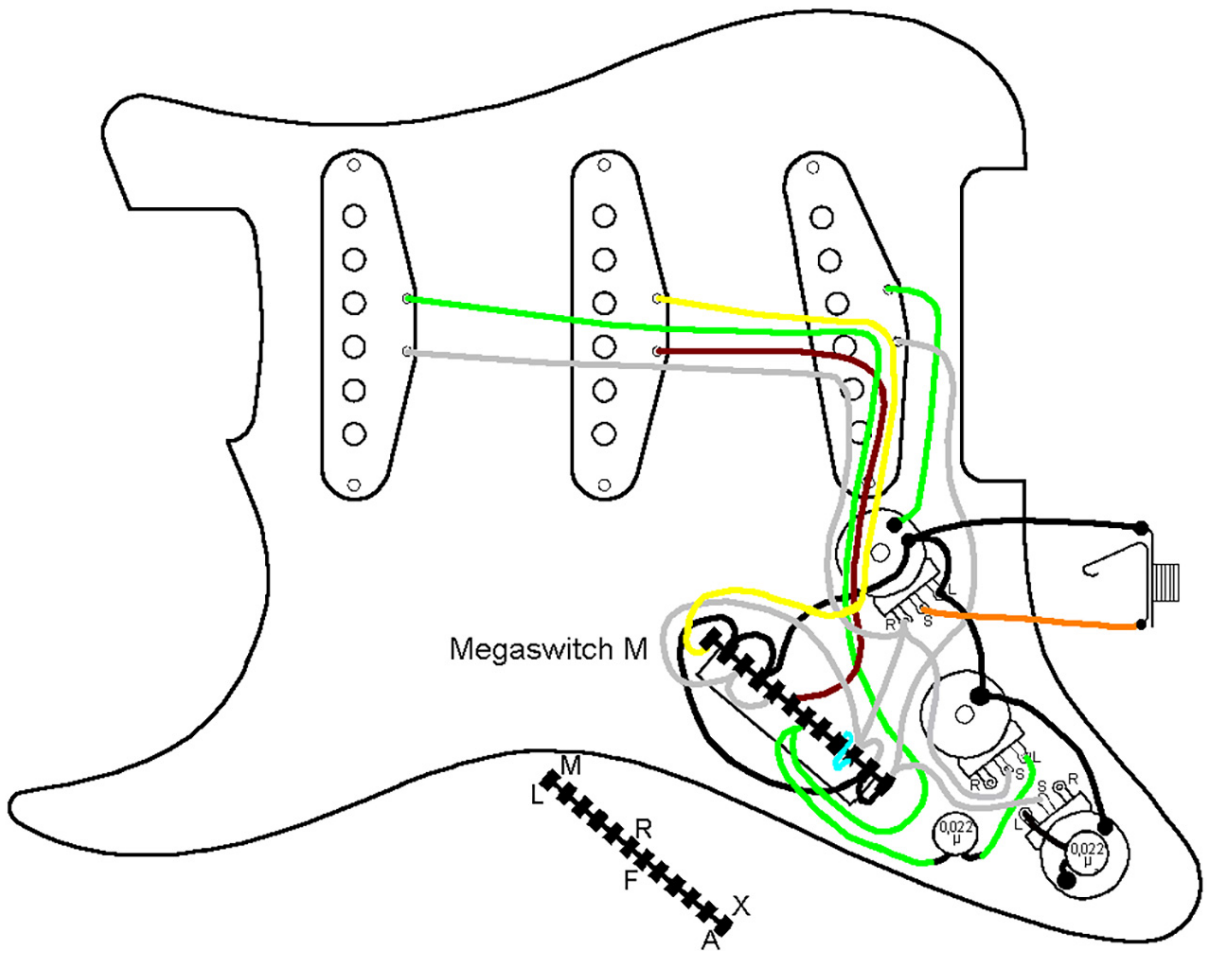

Connections:

Positions

- 1 bridge
- 2 bridge and mid parallel
- 3 bridge and neck in series
- 4 mid and neck parallel
- 5 neck

Connections

- A to B, N, P, ground
- B to A, N, P, ground
- C to U
- D -
- E -
- F neck cold wire
- G -
- H to J, V, W, output
- I -
- J to H, V, W, output
- K -
- L mid hot wire
- M -
- N to A, B, P, ground
- O -
- P to A, B, N, ground
- Q -
- R mid cold wire
- S -
- T -
- U to C
- V to H, J, W, output
- W to H, J, V, output
- X bridge hot wire
- ground: A, B, N, P, bridge cold wire

SSS5

This version enables a number of configurations, including three different switching-in-series positions.

- Position 1: Bridge pickup only.
- Position 2: Bridge and middle pickup in series
- Position 3: Bridge and neck pickups in series
- Position 4: Middle and neck pickups in series
- Position 5: Neck pickup only

This configuration range requires the Megaswitch M. When the connections between O and U are not made, all three pickups are switched in series in position 3. Just one tone control is advisable here. The following magnetic orientation creates a buzz-free sound in positions 2 and 4: S-N-S or N-S-N. When a buzz-free sound is required in position 3, the neck and middle pickup should be exchanged, which in turn creates buzz in position 2. Another solution is to exchange the middle and bridge pickups which creates buzz in position 4 however.

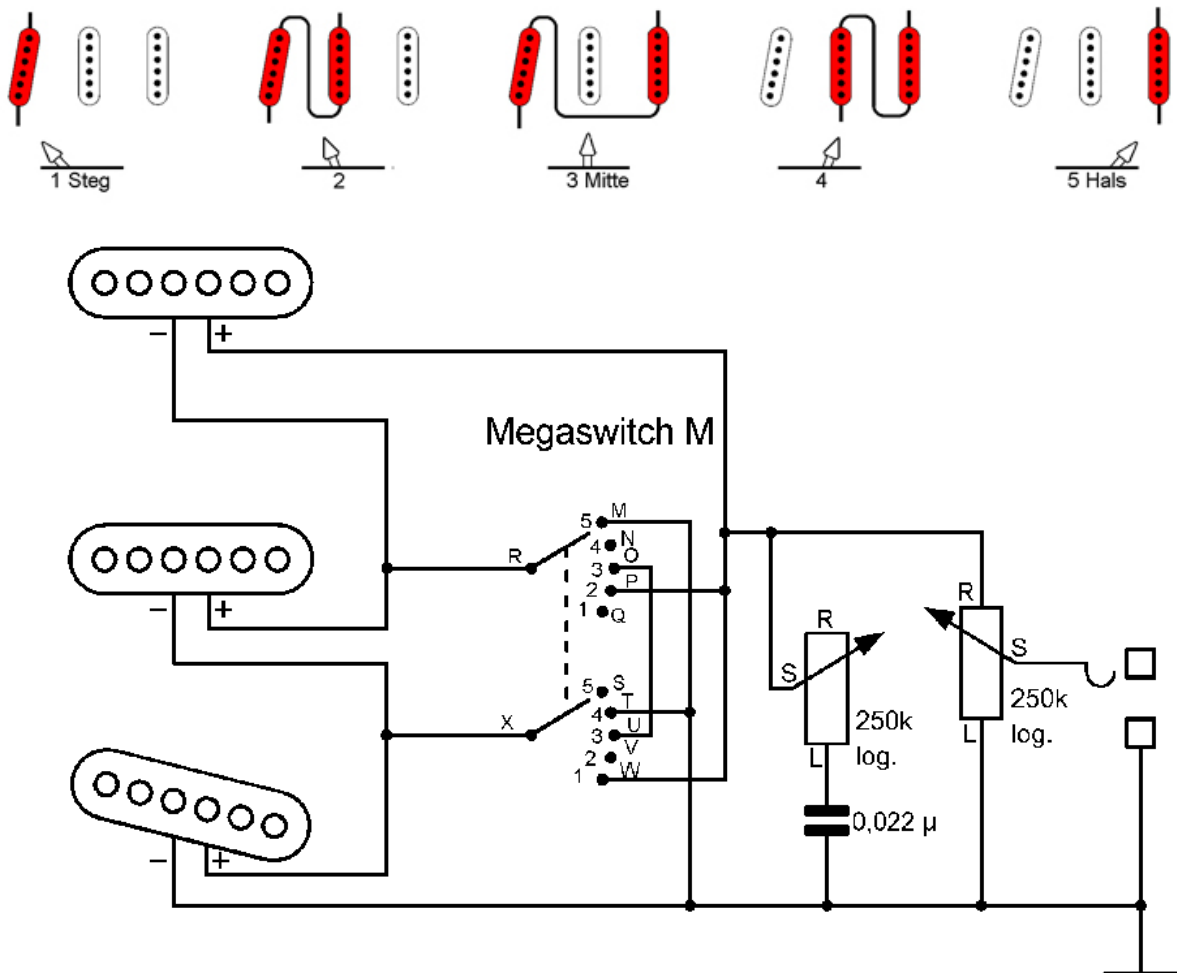

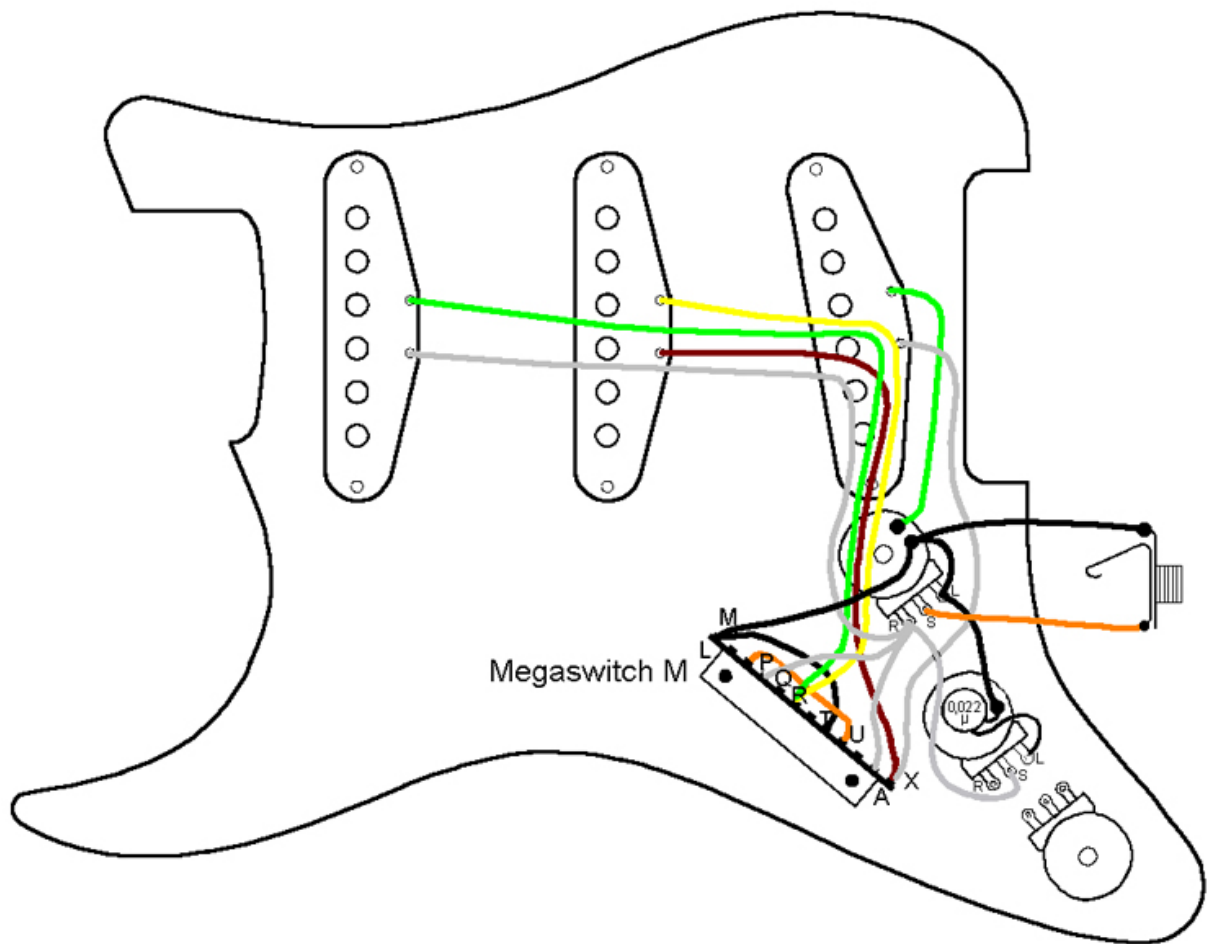

Connections:

Positions

- 1 bridge
- 2 bridge and mid in series
- 3 bridge and neck in series
- 4 mid and neck in series
- 5 neck

Connections

- M to T and ground
- N -
- O to U
- P to W, neck hot wire, output
- Q -
- R mid hot wire and neck cold wire
- S -
- T to M and ground
- U to O
- V -
- W to P, neck hot wire, output
- X bridge hot wire and mid cold wire
- ground: M, T, bridge cold wire

HH5

Here, the Humbuckers are split in position 2 and 4, although the outer coils remain in active mode. By reversing the coil connections, it is also equally possible to configure both inner coils, or one inner and one outer coil in active mode. A buzz-free sound can be obtained by making a north pole and a South Pole coil work together. The Megaswitch M is ideal for this purpose.

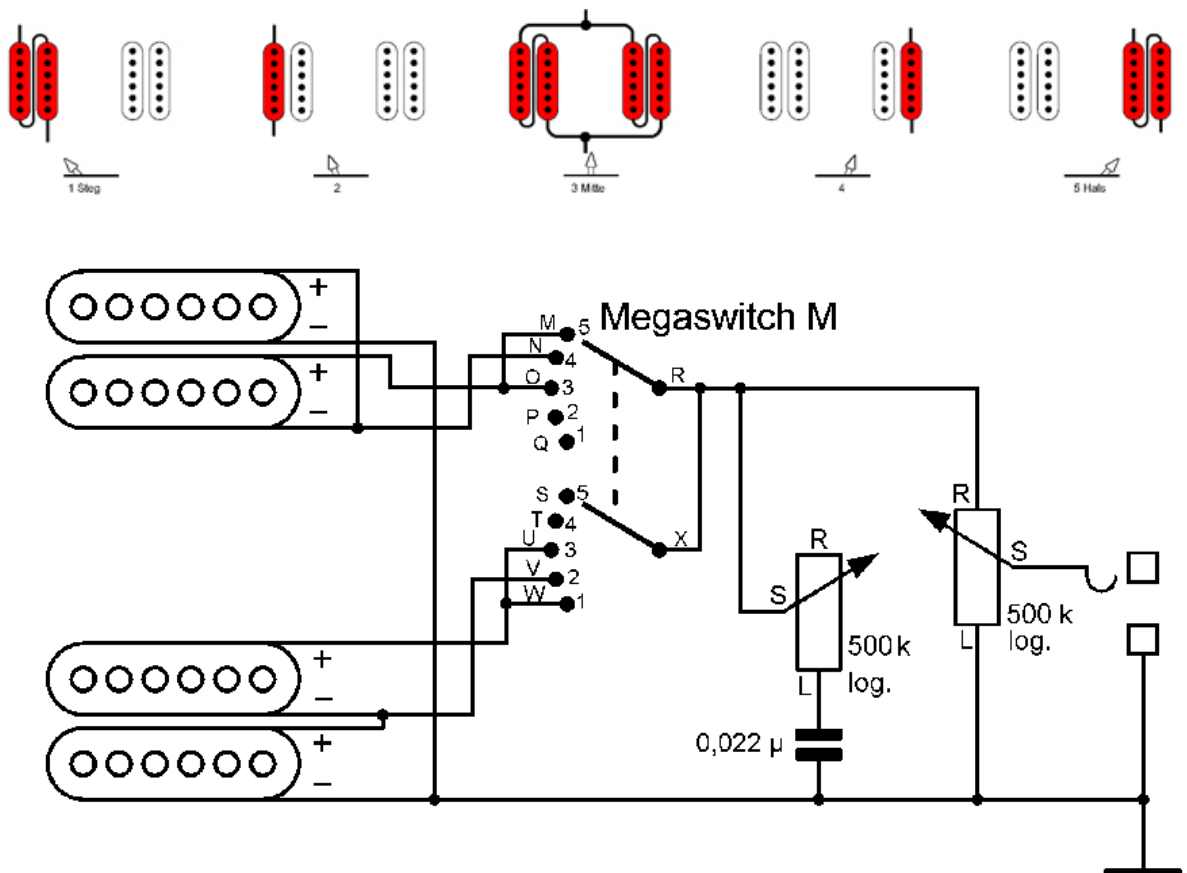

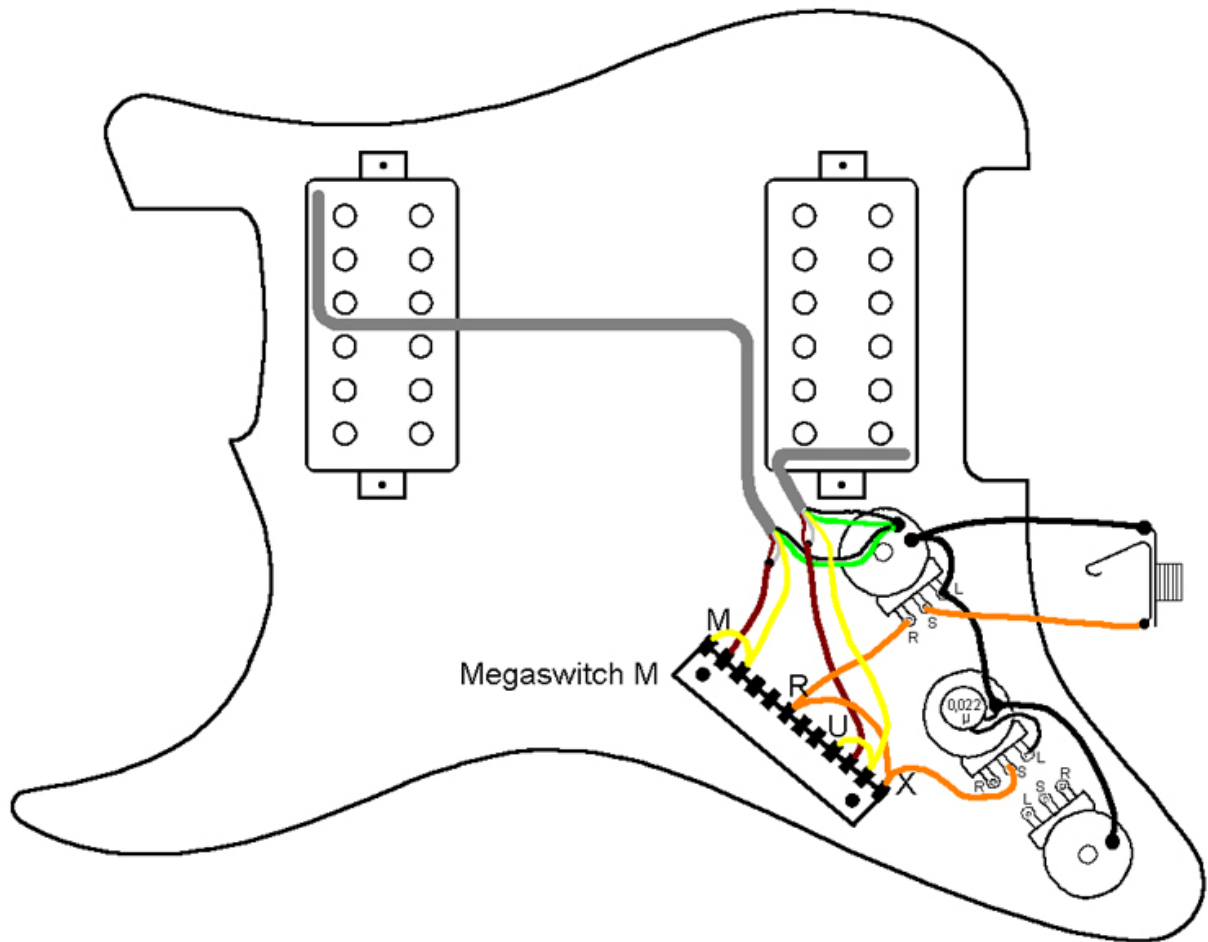

Connections:

Positions

- 1 bridge humbucker
- 2 bridge outer coil
- 3 both humbuckers parallel
- 4 neck outer coil
- 5 neck humbucker

Connections

- M to O, neck hot wire inner coil
- N neck cold wire inner coil and hot wire outer coil
- O to M, neck hot wire inner coil
- P -
- Q -
- R to X, output
- S -
- T -
- U to W, bridge hot wire inner coil
- V bridge hot wire outer coil and cold wire inner coil
- W to U, bridge hot wire inner coil
- X to R, output
- ground: neck and bridge cold wire outer coil

HH6

This is a variation on the HH5. Here, both Humbuckers are split in position 3. The sound is brighter as a result. By reversing the coil connections, it is equally possible to make both inner coils or an inner coil and an outer one to remain in operating mode. A buzz-free sound can be obtained when a north pole coil and a south pole coil remain active. The Megaswitch M is ideal for this purpose.

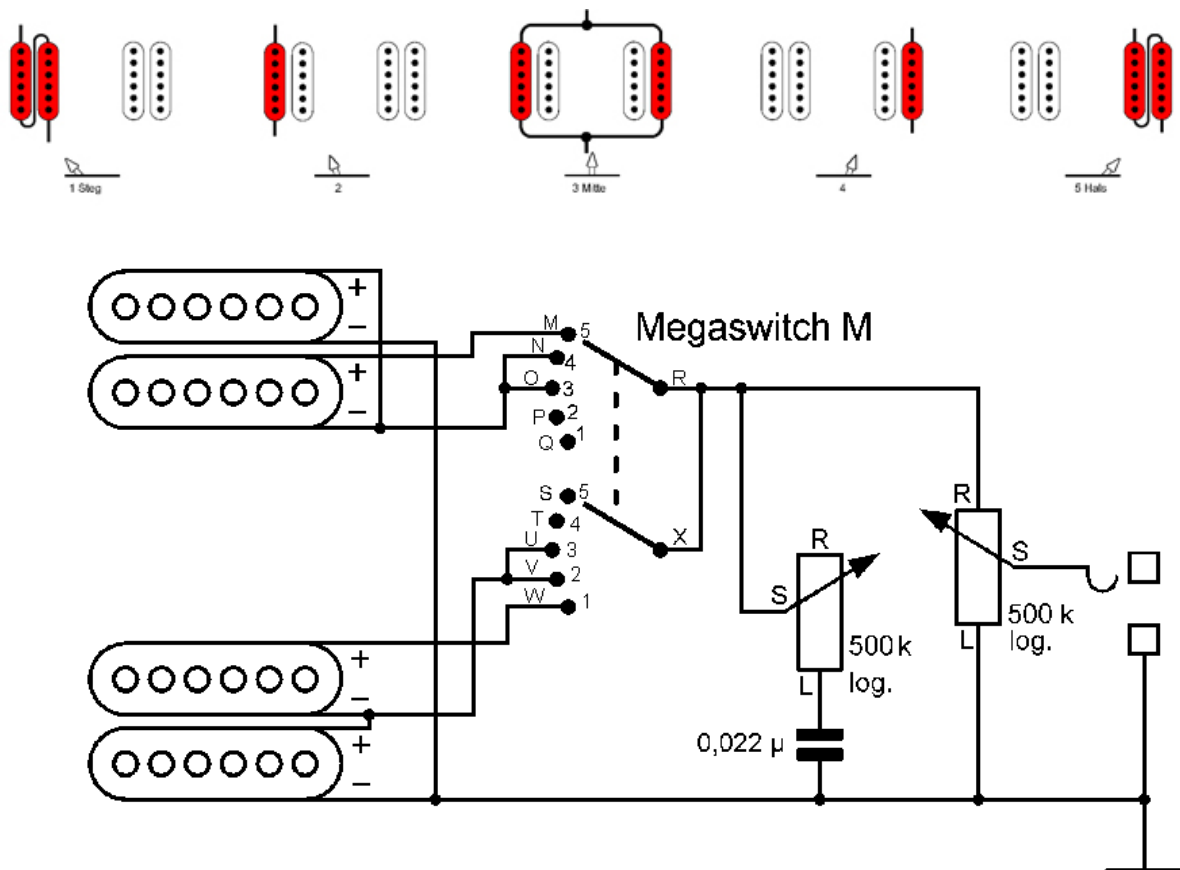

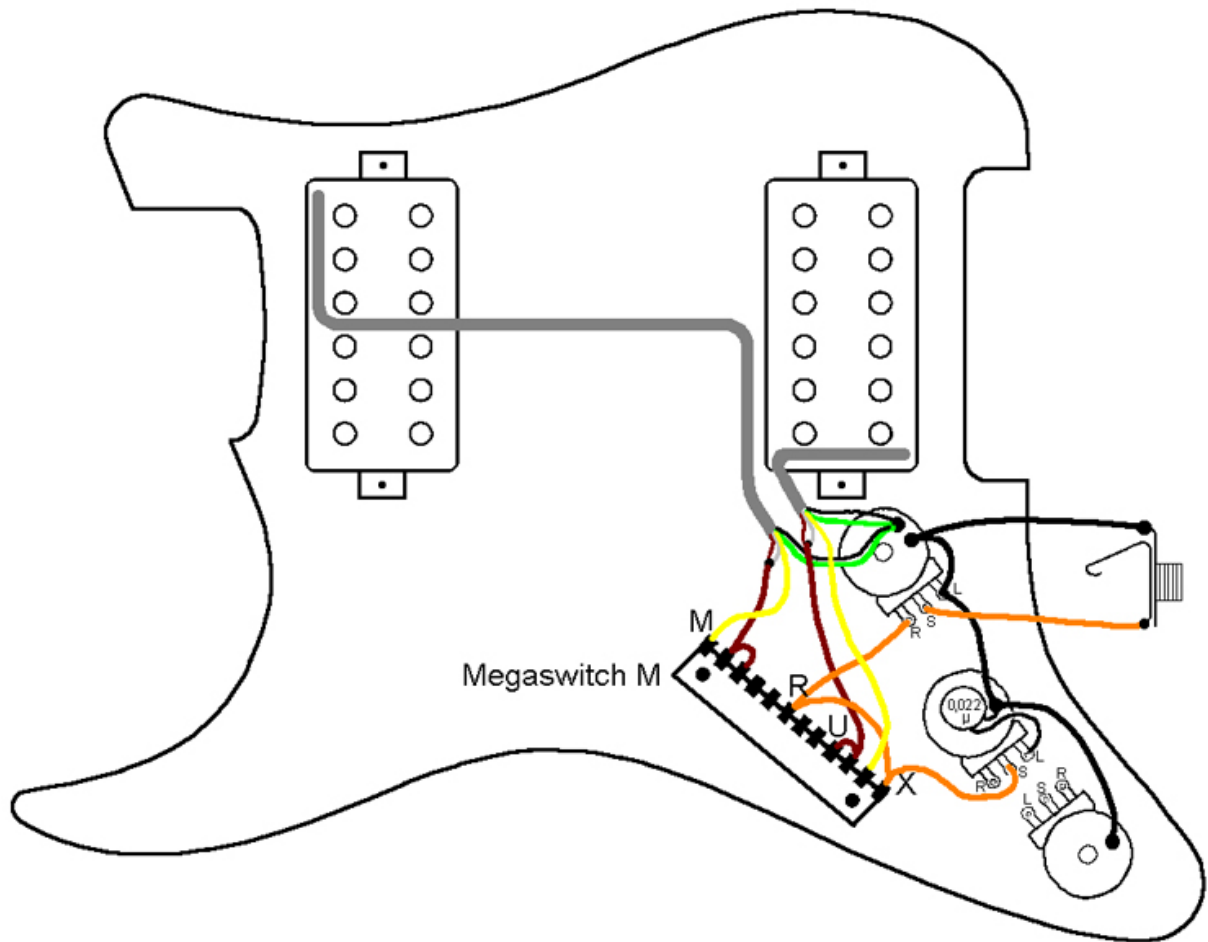

Connections:

Positions

- 1 bridge humbucker
- 2 bridge outer coil
- 3 outer coils parallel
- 4 neck outer coil
- 5 neck humbucker

Connections

- M neck hot wire inner coil
- N to O, neck cold wire inner coil and hot wire outer coil
- O to N, neck cold wire inner coil and hot wire outer coil
- P -
- Q -
- R to X, output
- S -
- T -
- U to V, bridge hot wire outer coil and cold wire inner coil
- V to U, bridge hot wire outer coil and cold wire inner coil
- W bridge hot wire inner coil
- X to R, output
- ground: neck and bridge cold wire outer coils

HH8

Here, the coils of the Humbucker are switched parallel in positions 2 and 4. All positions are buzz-free. The Megaswitch M is ideal for this purpose.

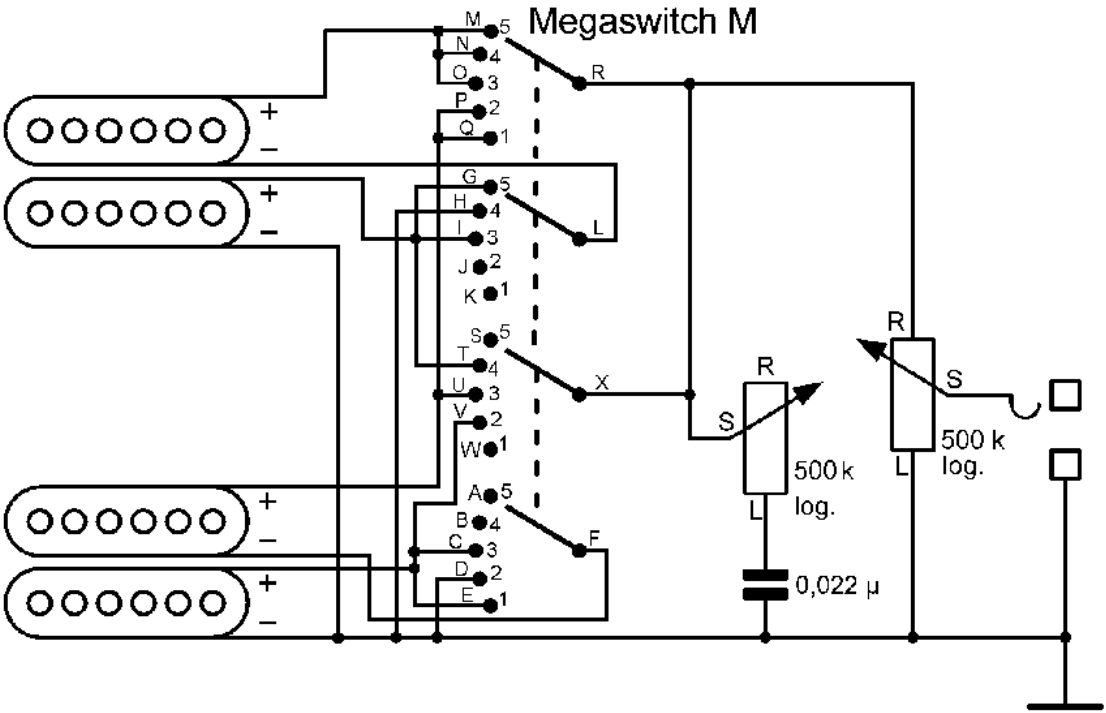
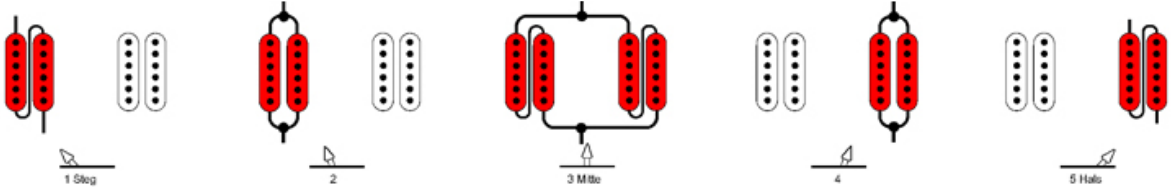

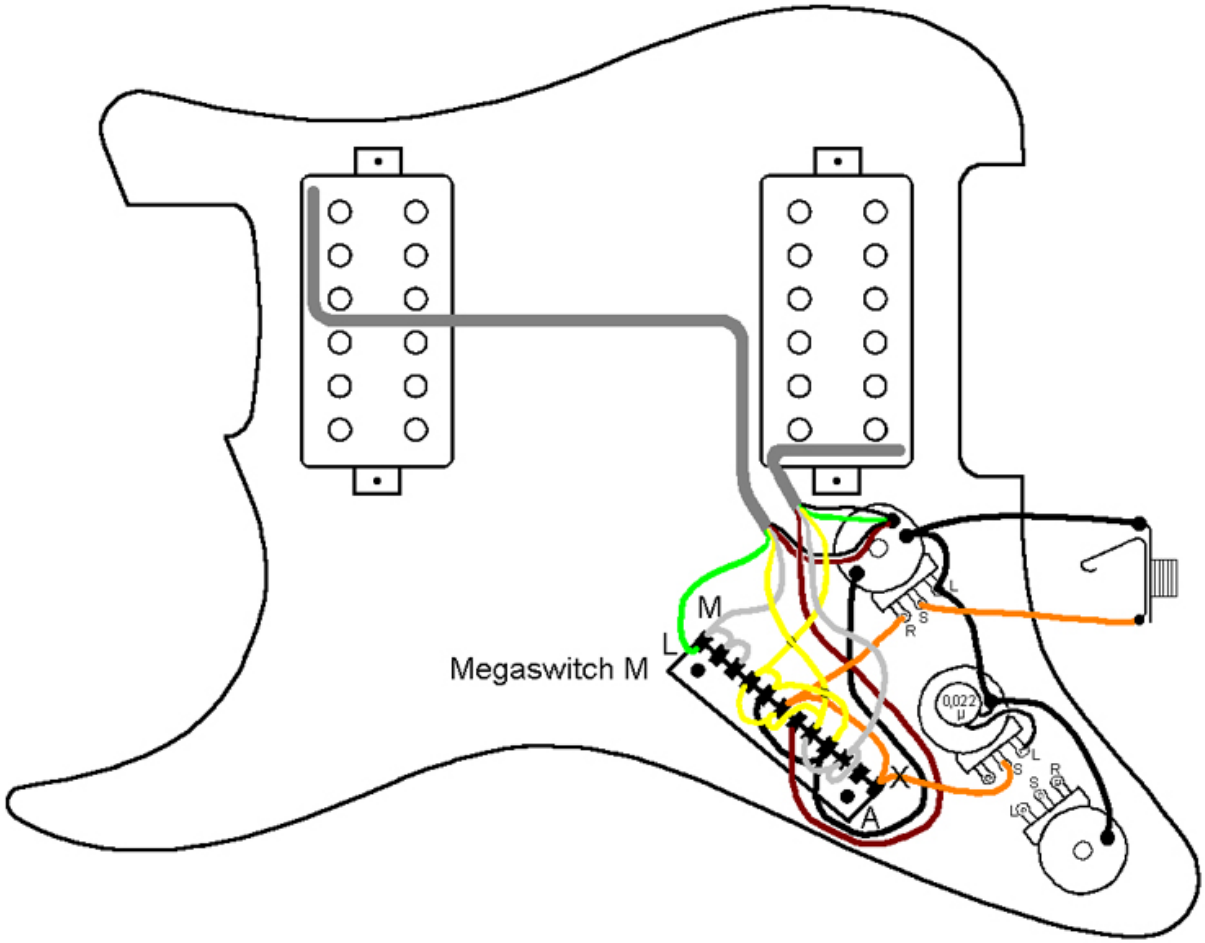

Connections:

Positions

- 1 bridge humbucker in series
- 2 bridge humbucker parallel
- 3 both humbuckers (each in series) parallel
- 4 neck humbucker parallel
- 5 neck humbucker in series

Connections

A -

B -

C to E and V, bridge hot wire outer coil

D to H and ground

E to C and V, bridge hot wire outer coil

F bridge cold wire inner coil

G to I and T, neck hot wire inner coil

H to D and ground

I to G and T, neck hot wire inner coil

J -

K -

L neck cold wire outer coil

M to N and O, neck hot wire outer coil

N to M and O neck hot wire outer coil

O to N and M, neck hot wire outer coil

P to Q and U, bridge hot wire inner coil

Q to P and U, bridge hot wire inner coil

R to X and output

S -

T to G and I, neck hot wire inner coil

U to P and Q, bridge hot wire inner coil

V to C and E, bridge hot wire outer coil

W -

X to R and output

ground: D, H, neck cold wire inner coil, bridge cold wire outer coil

HH10

With this circuit, the coil combinations described in some Ibanez guitars include:

1. Bridge humbuckers in series
2. inner coils in parallel
3. Both humbuckers in parallel, each in series
4. Neck humbucker in parallel
5. Neck humbuckers in series

The positions 1, 3, 4 and 5 are always free of hum. Even if position 2 should be hum-free, then the magnetic polarity must of the coils can be NS-NS or SN-SN.

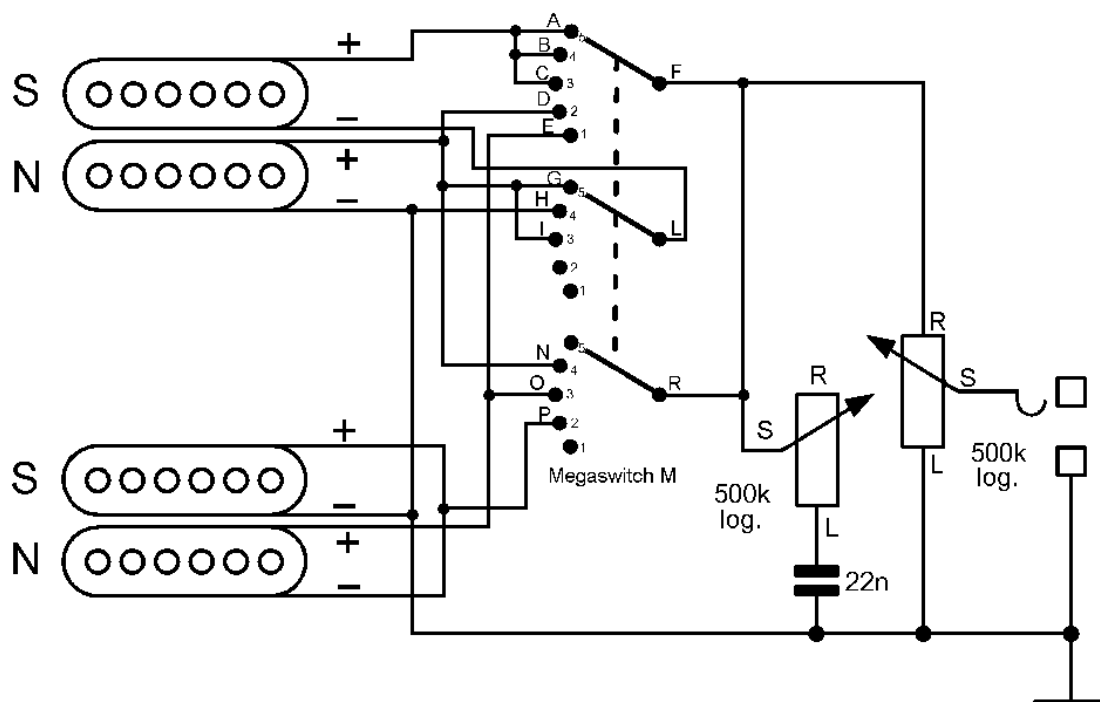
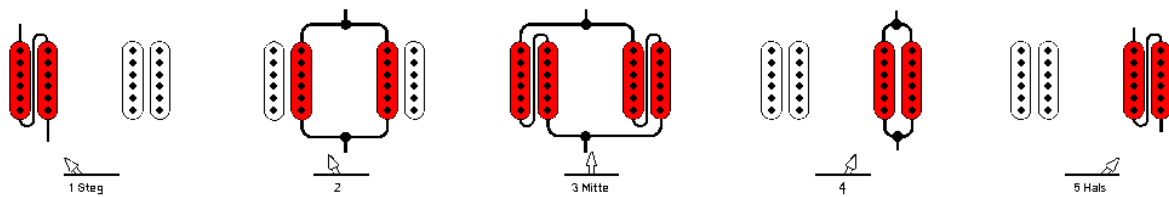

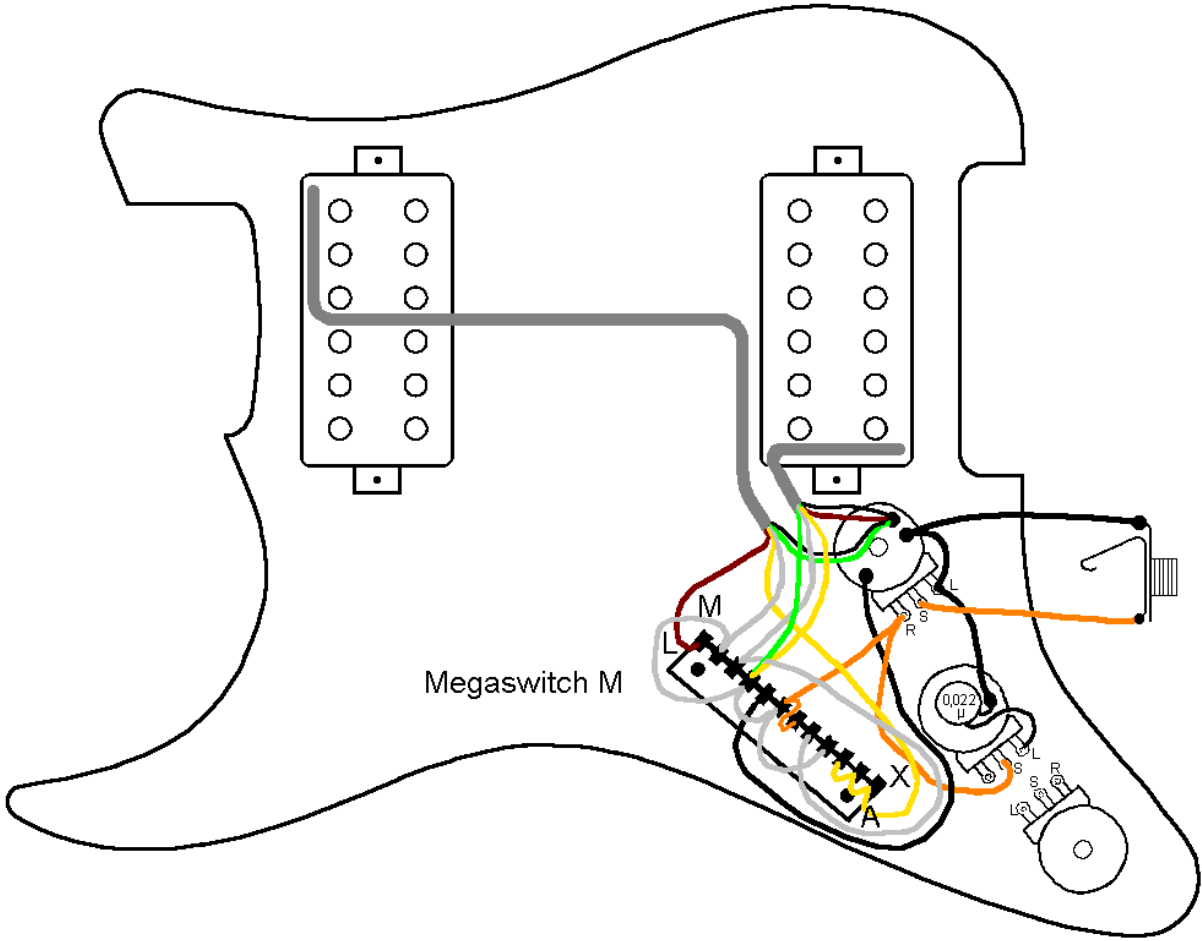

Connections:

Positions

1. Bridge humbucker in series
2. Inner coils in parallel
3. Both humbucker in parallel, each one in series
4. Neck humbucker parallel
5. Neck humbucker in series

Connections

A, B, C hot connector outer coil neck humbucker

D, G, I, N hot connector inner coil neck humbucker

E, O hot wire outer coil bridge humbucker

F, R volume control right stop and tone control slider

H ground

J, K -

L cold connection outer coil neck humbucker

M -

P hot connection inner coil bridge humbucker and cold connection outer coil bridge humbucker

Q, S, T, U, V, W, X -

HH11. Five positions, combinations as for PRS, Megaswitch M

1. Bridge-Humbucker
2. Bridge-Humbucker and Neck as Singlecoil parallel
3. both Humbucker parallel
4. Bridge-Singlecoil and Neck-Singlecoil parallel
5. Neck-Humbucker

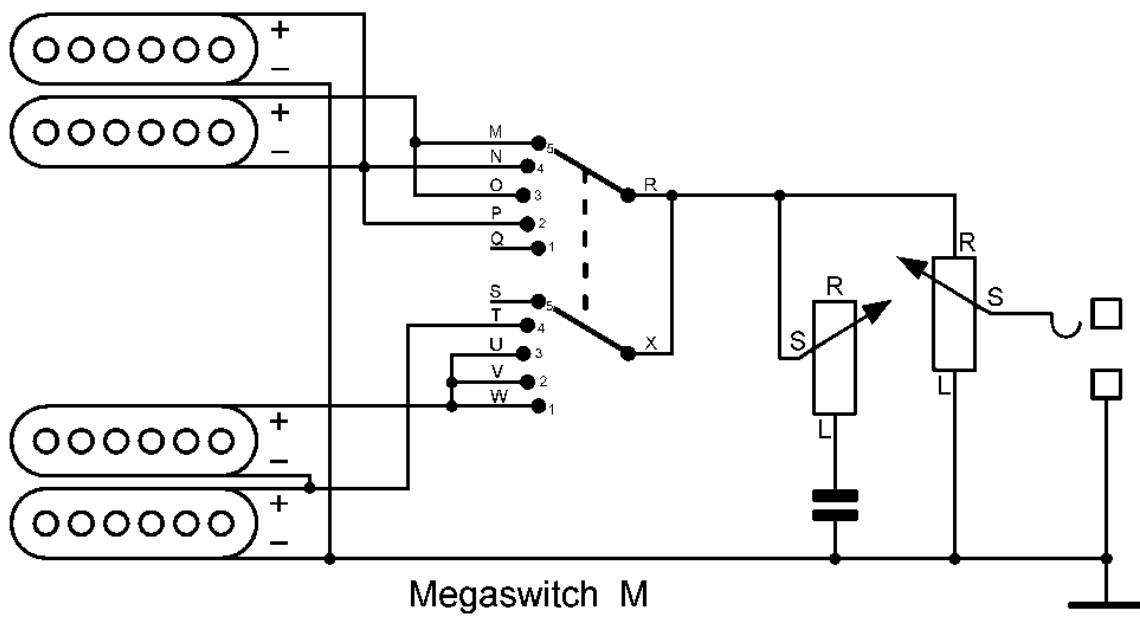
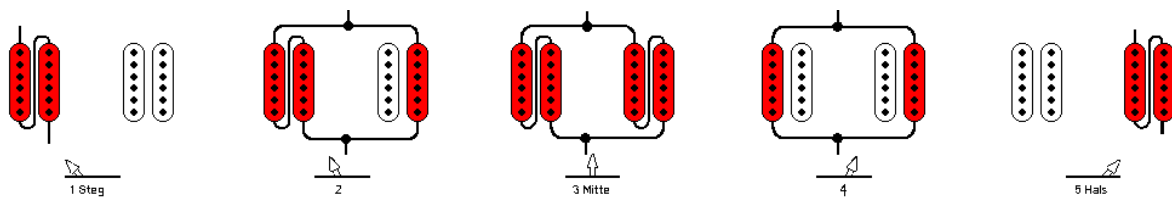

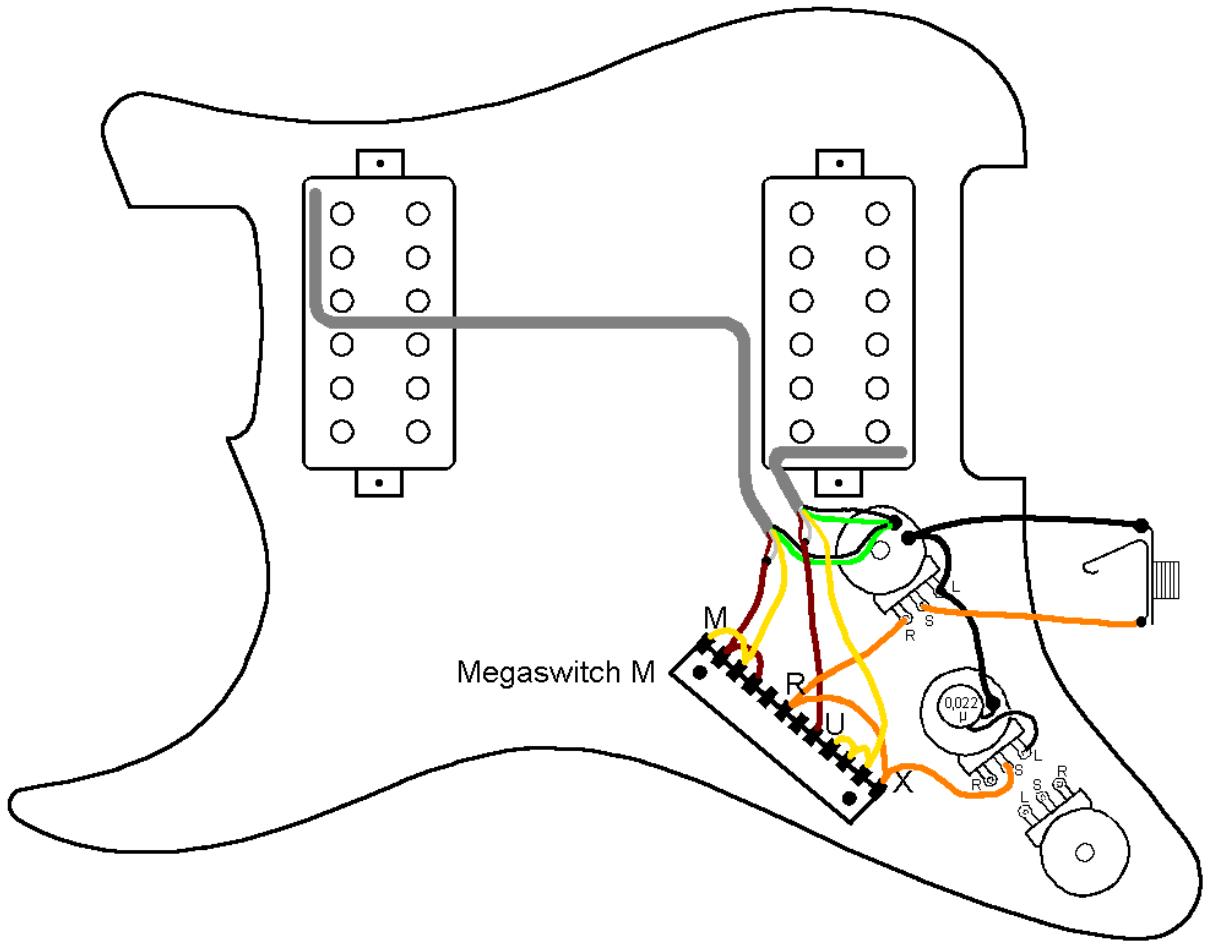

Connections:

position

1 bridge humbucker

2 bridge humbucker and neck outer coil parallel

3 both in parallel

4 outer coils in parallel

5 neck humbucker

connections

A ... L

M, O hot connection neck inner coil

N, P hot connection neck outer coil and cold connection neck inner coil

Q, S-

R, X volume control right connection and tone control slider

T hot connection bar outer coil and cold connection bar inner coil

U, V, W hot connection bar inner coil

HH12. Five positions, similar to HH11, Megaswitch M

1. Bridge-Humbucker
2. Bridge-Humbucker and Neck as Singlcoil parallel
3. both Humbucker parallel
4. Bridge-Singlecoil and Neck-Humbucker parallel
5. Neck-Humbucker

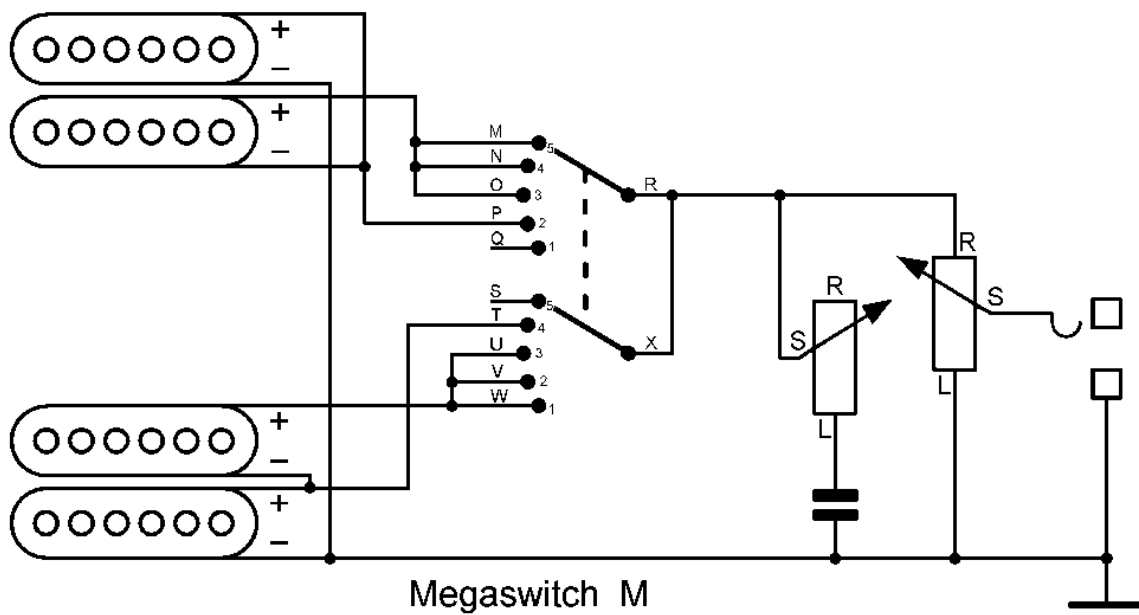
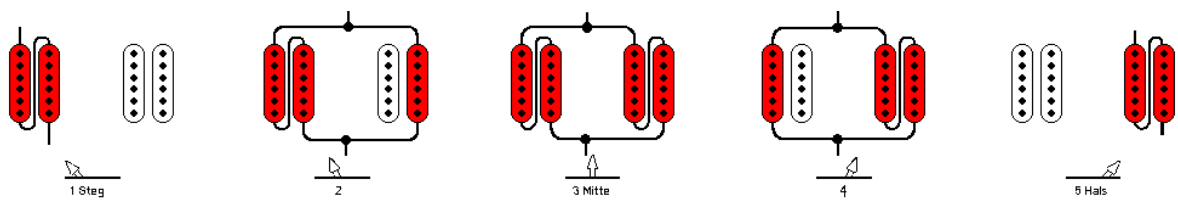

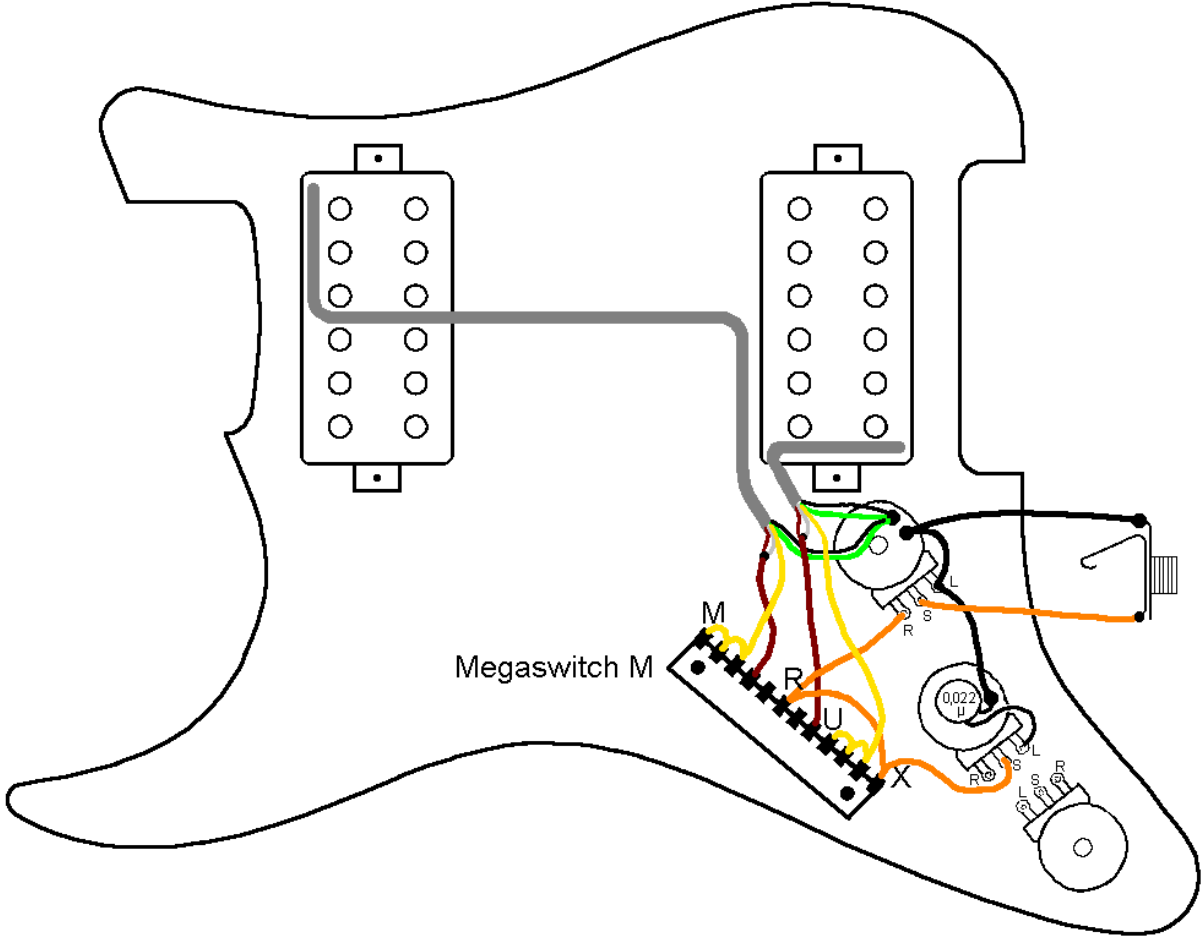

Connections:

position

1 bridge humbucker

2 bridge humbucker and neck outer coil parallel

3 both in parallel

4 bridge outer coil and neck humbucker parallel

5 neck humbucker

connections

A ... L-

M, N, O hot connection neck inner coil

P hot connection neck outer coil and cold connection neck inner coil

Q, S-

R, X volume control right connection and tone control slider

T hot connection bar outer coil and cold connection bar inner coil

U, V, W hot connection bar inner coil

HSH6

In this switching system two coils are connected in series at a time. All positions are free of hum when the magnetic polarity is NS-S-SN or SN-N-NS. Here a Megaswitch M is in use.

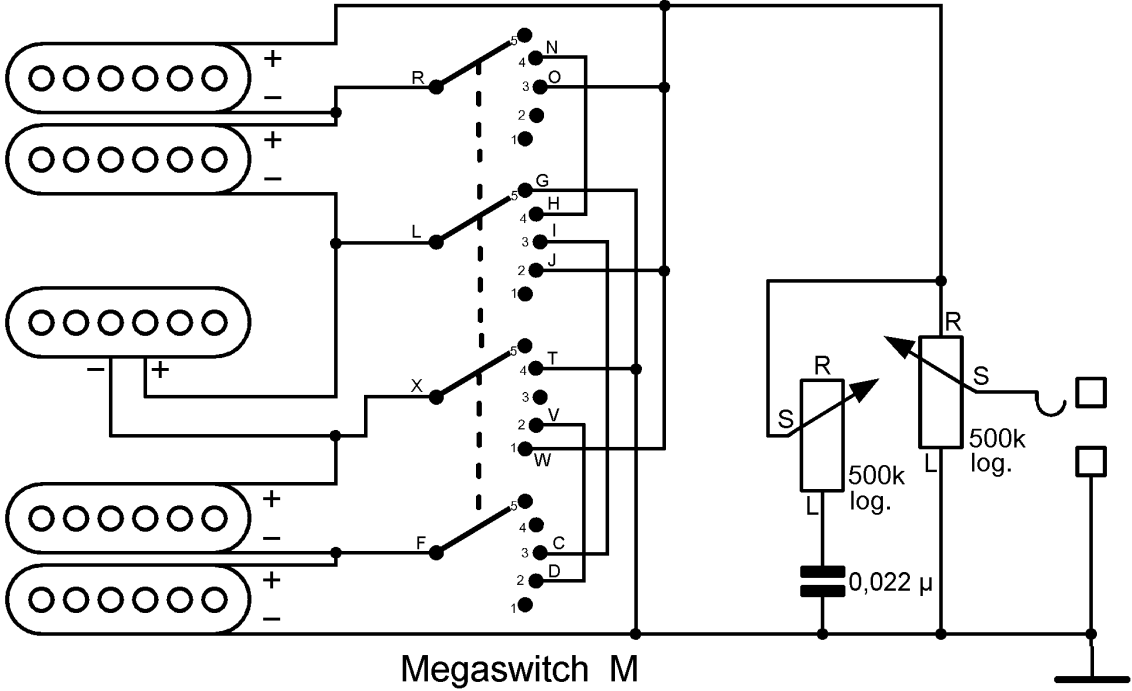
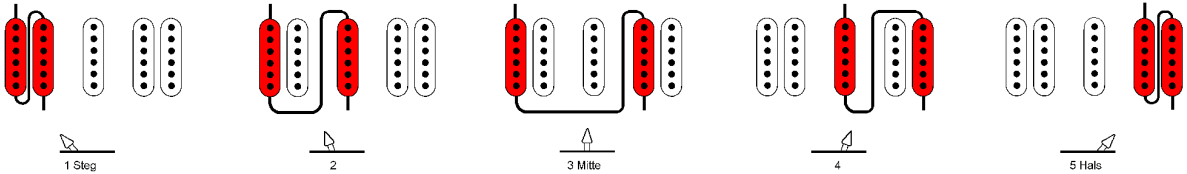

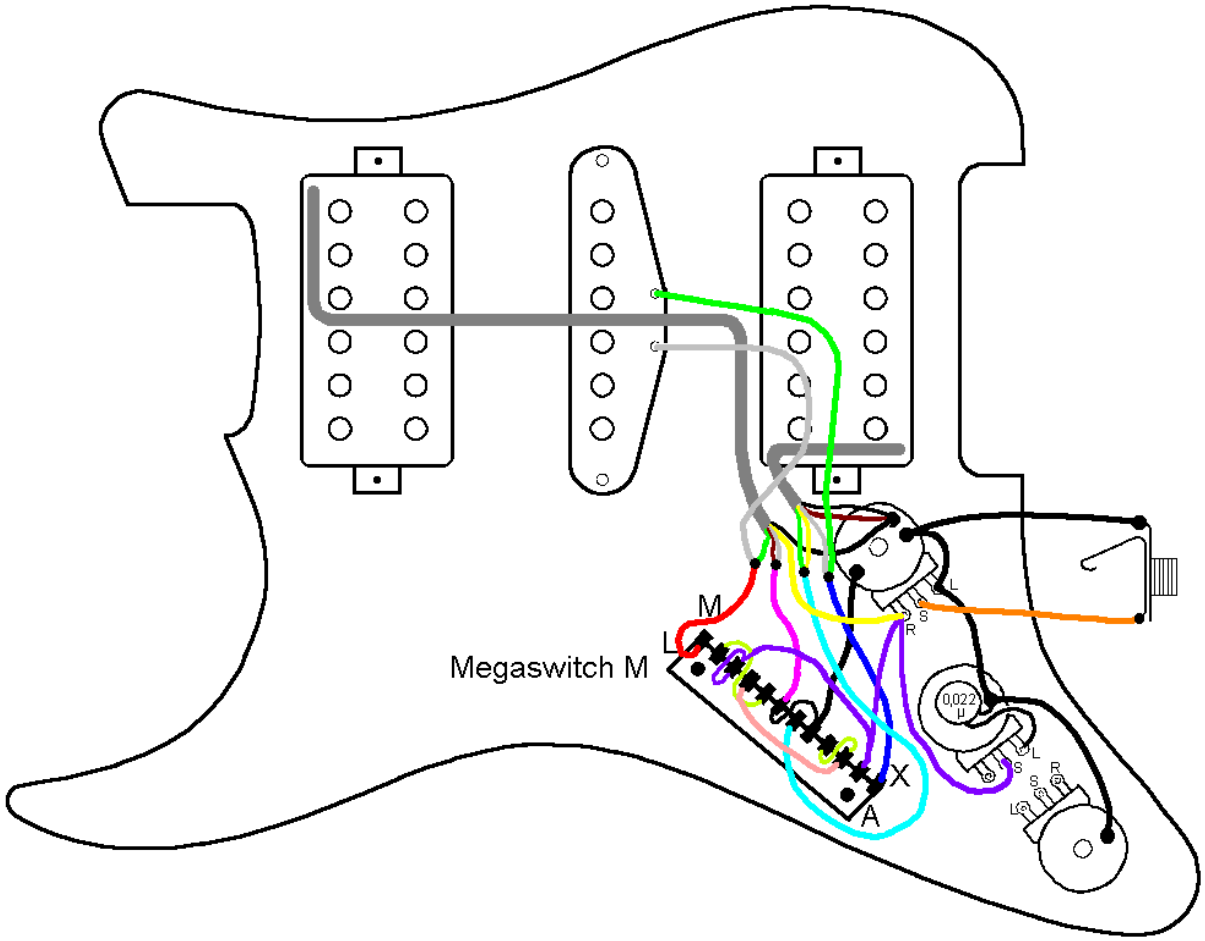

Connections:

Positions

- 1 bridge humbucker
- 2 bridge outer coil and mid in series
- 3 bridge outer coil and neck inner coil in series
- 4 mid and neck outer coil in series
- 5 neck humbucker

Connections

- A -
- B -
- C to I
- D to V
- E -
- F bridge hot wire outer coil and cold wire inner coil
- G to T and ground
- H to N
- I to C
- J to O, W, neck hot wire outer coil and output
- K -
- L mid hot wire and neck cold wire inner coil
- M -
- N to HH
- O to J and W, neck hot wire outer coil and output
- P -
- Q -
- R neck hot wire inner coil and cold wire outer coil
- S -
- T to G and ground
- U -
- V to D
- W to J, O, neck hot wire outer coil and output
- X bridge hot wire inner coil, mid cold wire
ground: G, T, bridge cold wire outer coil

HS4

This switching system is for guitars with a Humbucker on the bridge and a single coil on the neck and allows both pickups to be switched in series which creates a lower, fuller sound. Here, the Humbuckers can be split while the outer coil remains active. The inner coil is short-circuited. If a buzz-free sound is required in position 4, the magnetic polarity must be either NS-S or SN-N. The neck pickup has to be a symmetrical type, as in Figure 1 or Figure 3 in the introduction, i.e. the wire windings should not be connected to a metal cap. Here, the Megaswitch M is used.

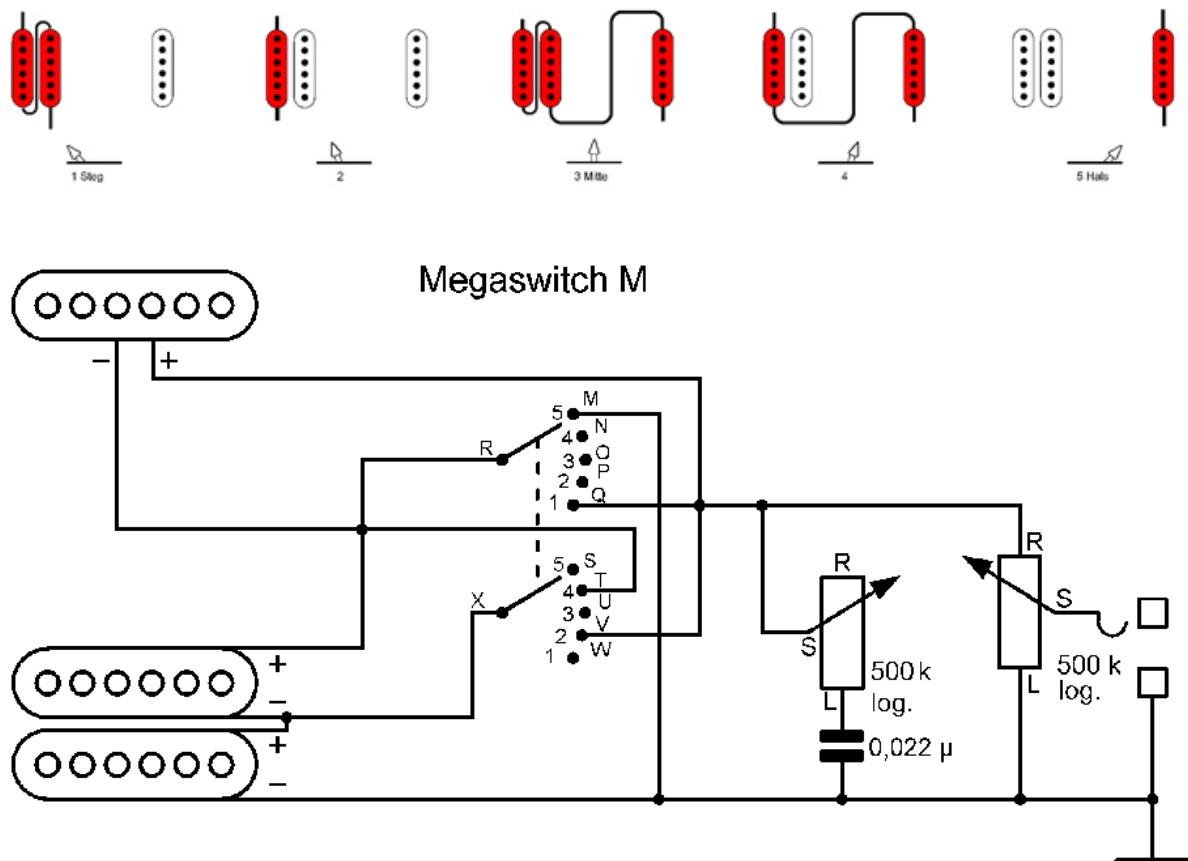

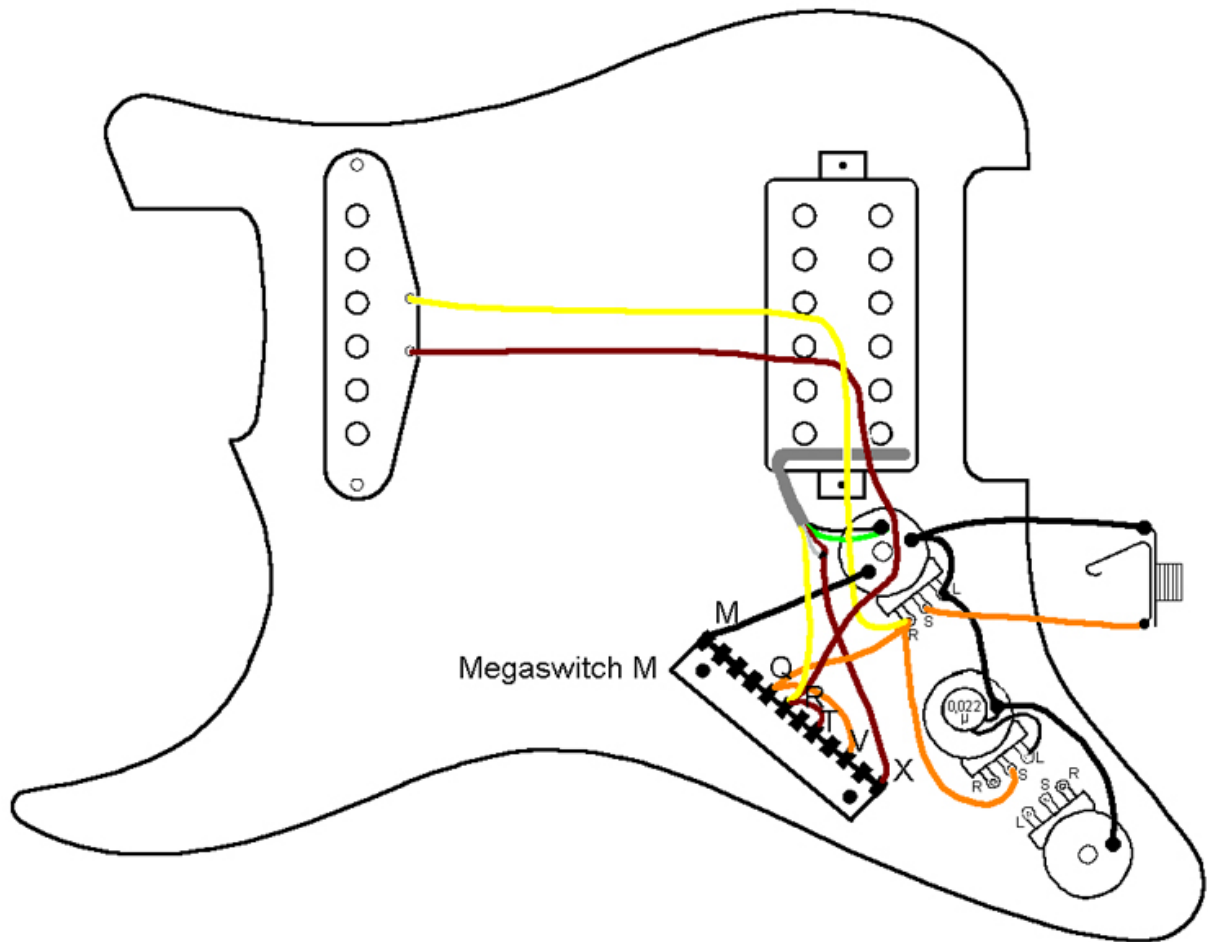

Connections:

Positions

- 1 bridge humbucker
- 2 bridge outer coil
- 3 bridge humbucker and neck in series
- 4 bridge outer coil and neck in series
- 5 neck

Connections

- M ground
- N -
- O -
- P -
- Q to V, neck hot wire, output
- R to T, bridge hot wire inner coil and neck cold wire
- S -
- T to R, bridge hot wire inner coil and neck cold wire
- U -
- V to Q, neck hot wire, output
- W -
- X - bridge hot wire outer coil and cold wire inner coil
- ground: M, bridge cold wire outer coil

HS5

This switching system is for guitars with a Humbucker on the bridge and a single coil on the neck and allows both pickups to be switched in series, which creates a louder, fuller sound. Here, it is possible to split the Humbucker, while the inner coil remains active. The outer coil is short-circuited. The neck pickup has to be a symmetrical type such as in Figure 1 and 3 in the introduction, i.e the wire windings may not be connected to a metal cap. If a buzz-free sound is required in position 4, the magnetic polarity must be be NS-N or SN-S. Here, a Megaswitch M is used.

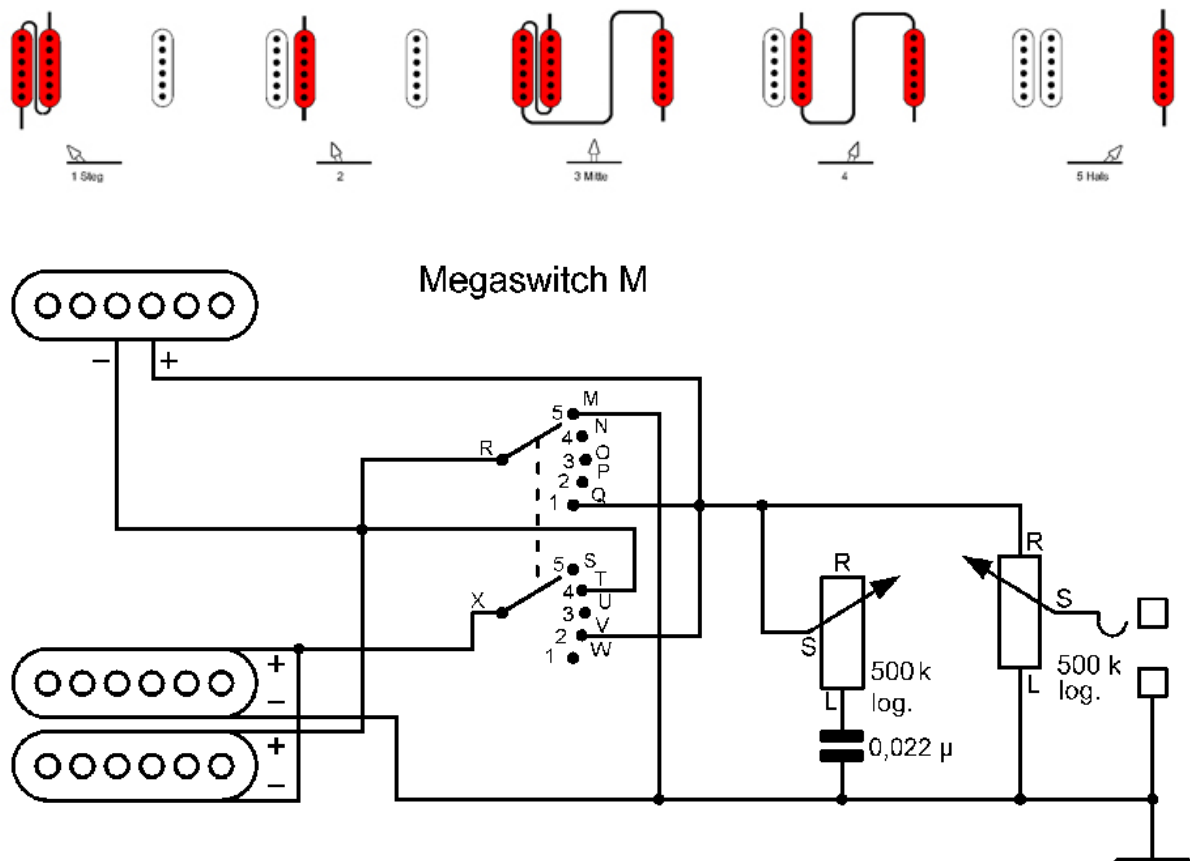

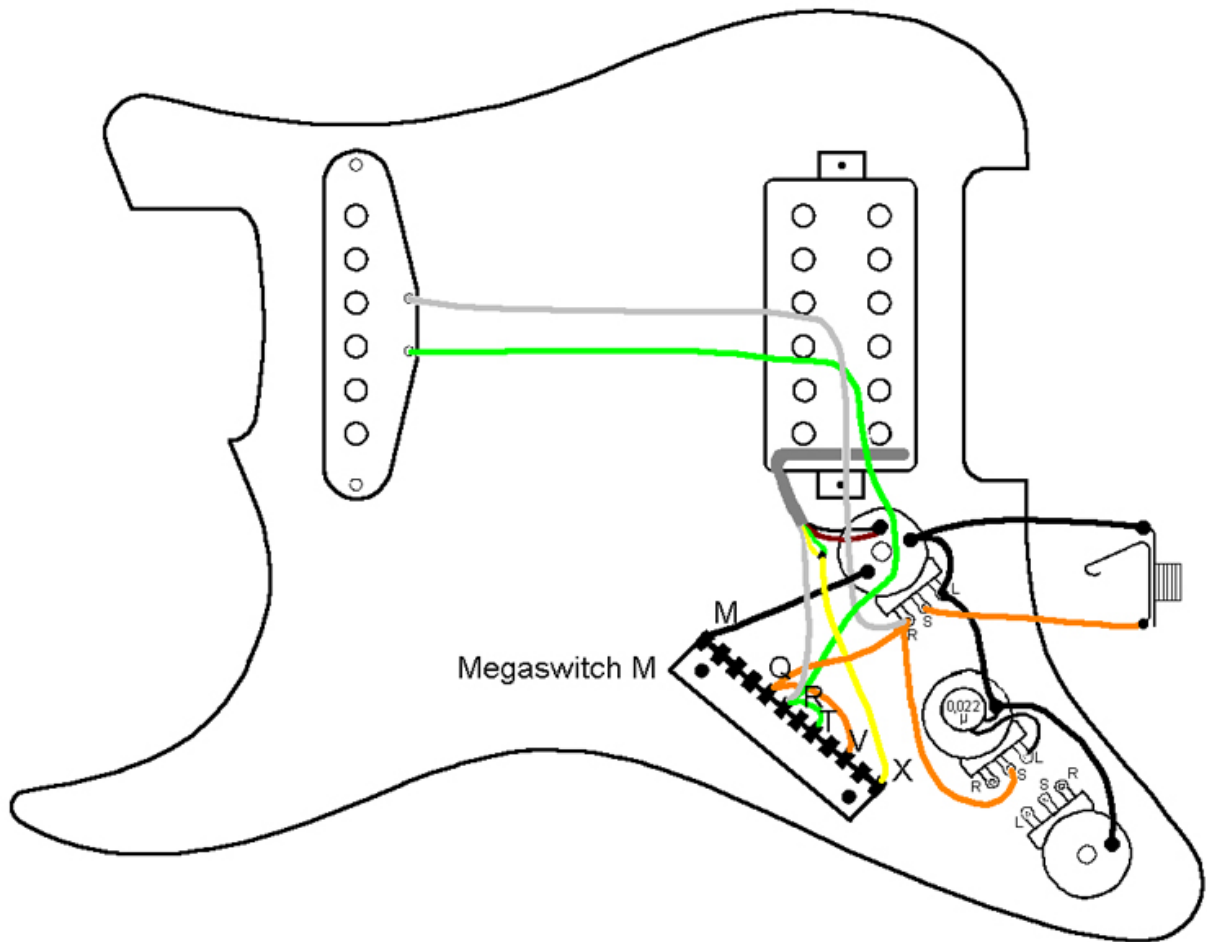

Connections:

Positions

- 1 bridge humbucker
- 2 bridge inner coil
- 3 bridge humbucker and neck in series
- 4 bridge inner coil and neck in series
- 5 neck

Connections

M ground

N -

O -

P -

Q to V, hot wire neck, output

R to T, bridge hot wire outer coil and neck cold wire

S -

T to R, bridge hot wire outer coil and neck cold wire

U -

V to Q, neck hot wire, output

W -

X bridge hot wire inner coil and cold wire outer coil

ground: M, bridge cold wire inner coil

SH4

This switching system is for guitars with a single coil on the bridge and a Humbucker on the neck. It allows both pickups to be switched in series which creates a louder, fuller tone. The Humbucker can be split while the outer coil remains active. The inner coil is short-circuited.

The Humbucker can be split while the outer coil remains active. The inner coil is short-circuited. The Megaswitch M is ideal for this purpose. If a buzz-free sound is required in position, the following magnetic polarity (from the bridge to the neck) is required: N-NS or S-SN.

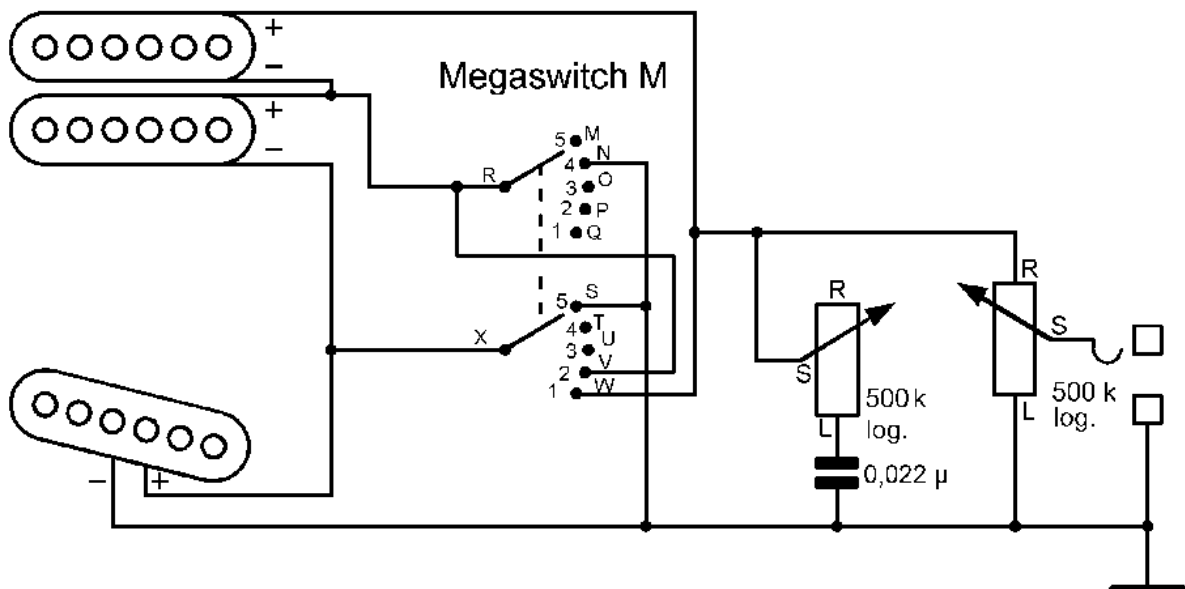
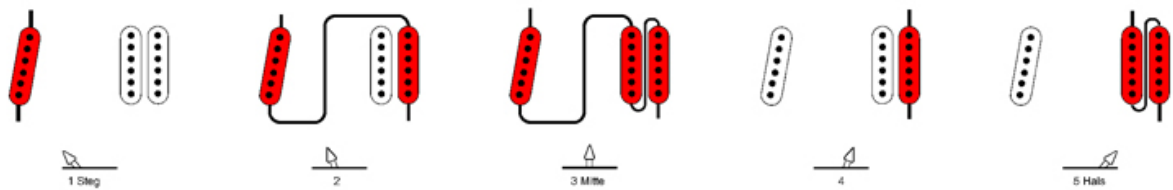

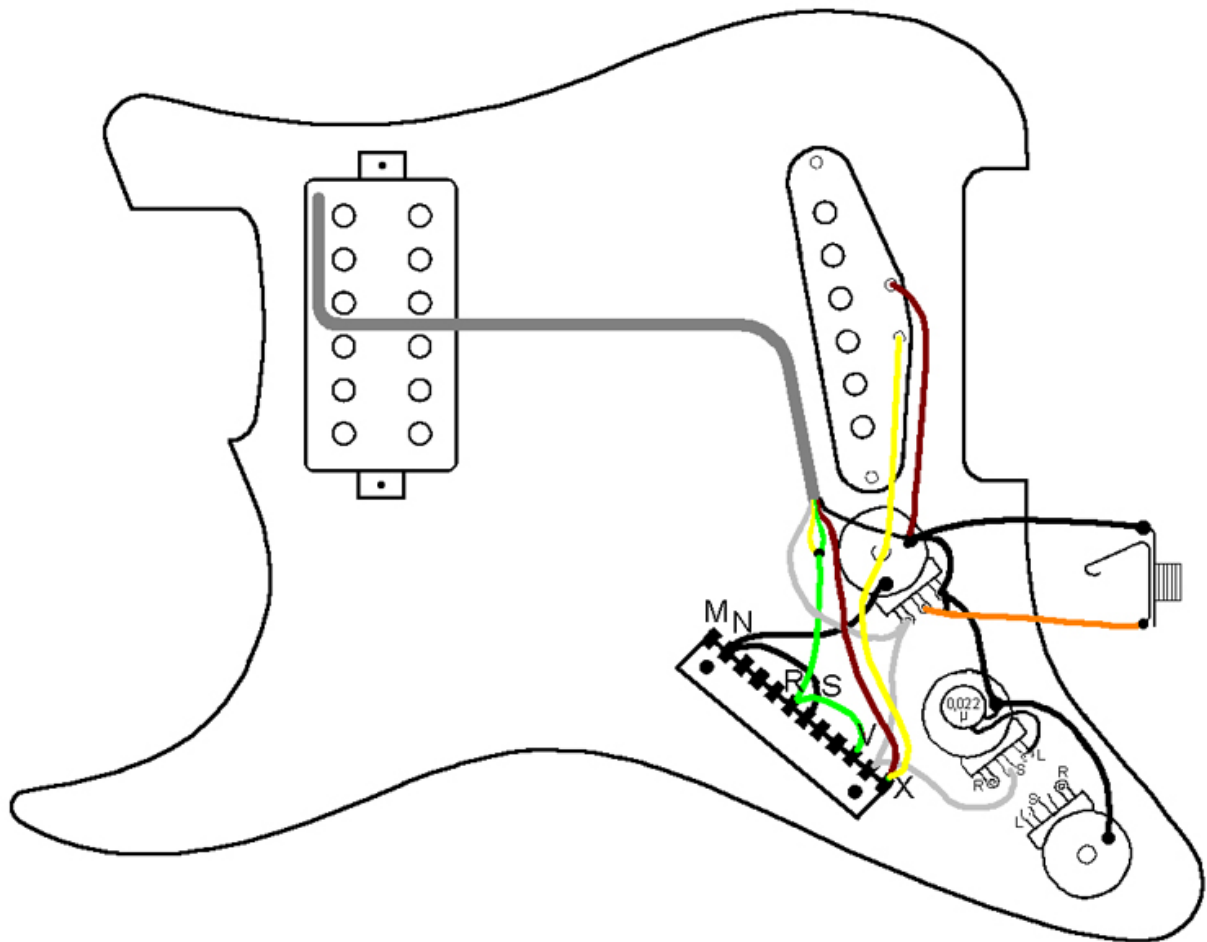

Connections:

Positions

- 1 bridge
- 2 bridge and neck outer coil in series
- 3 bridge and neck humbucker in series
- 4 neck outer coil
- 5 neck humbucker

Connections

- M -
- N to S and ground
- O -
- P -
- Q -
- R to V, neck cold wire outer coil and hot wire inner coil
- S to N and ground
- T -
- U -
- V to R, neck cold wire outer coil and hot wire inner coil
- W -
- X bridge hot wire and neck cold wire inner coil
- ground: N, S, bridge cold wire

SH5

This switching system is for guitars with a single coil on the bridge and a Humbucker on the neck. It allows both pickups to be switched in series which creates a louder, fuller tone. The Humbucker can be split while the inner coil remains active. The outer coil is short-circuited.

The Megaswitch M is ideal for this purpose. If a buzz-free sound is required in position 2, the following magnetic polarity is required: N-SN or S-NS.

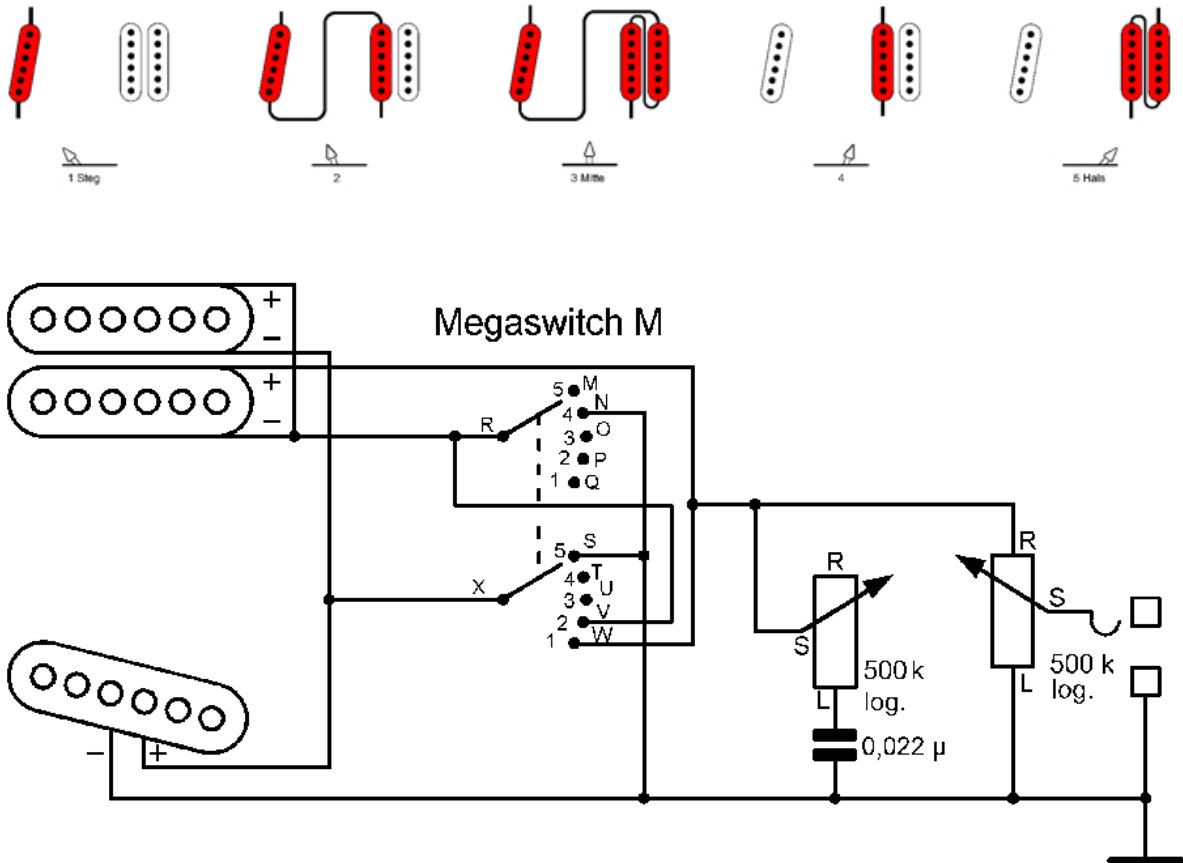

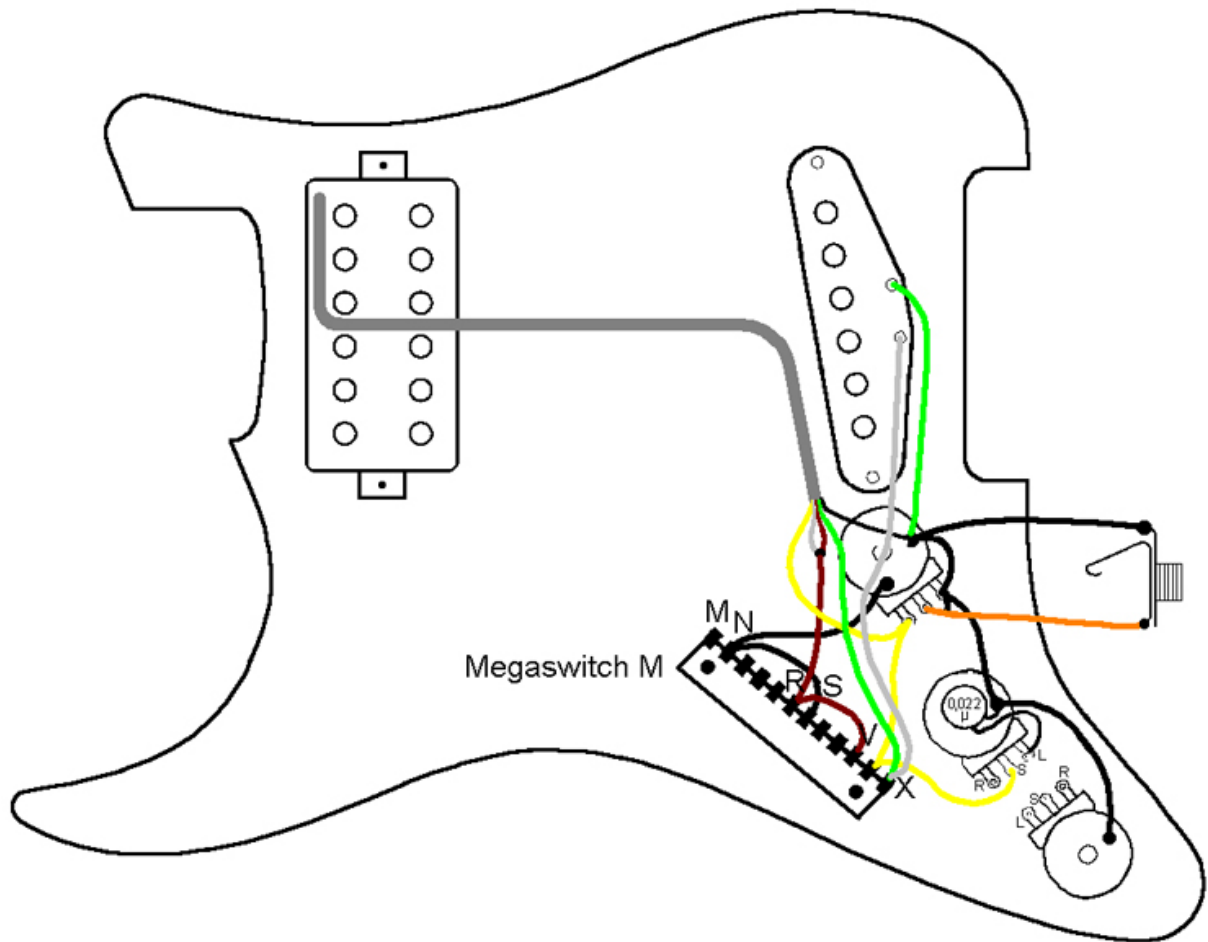

Connections:

Positions

- 1 bridge
- 2 bridge and neck inner coil in series
- 3 bridge and neck humbucker in series
- 4 neck inner coil
- 5 neck humbucker

Connections

- M -
- N to S and ground
- O -
- P -
- Q -
- R to V, neck cold wire inner coil and hot wire outer coil
- S to N and ground
- T -
- U -
- V to R, neck cold wire inner coil and hot wire outer coil
- W -
- X bridge hot wire and neck cold wire outer coil

SS3

This is a very versatile switching system for Telecaster-type guitars. The five-position switch produces the following combinations:

1. Bridge
2. Bridge and neck reverse phased and parallel
3. Bridge and neck phased and parallel
4. Bridge and neck phased and in series
5. Neck

Caution: Here, the base plate of the bridge pickup must be electrically isolated from the coil and earthed/grounded via a separate wire. The capacitor which is switched in series to the bridge pickup in position 2, improves the sound considerably by avoiding the weakening on the bass end of the sound spectrum usually associated with direct antiparallel mode. The value of $0.022 \mu\text{F}$ is a general guide only and can be increased or decreased as a matter of taste, depending on the resultant sound. The Megaswitch M is used here.

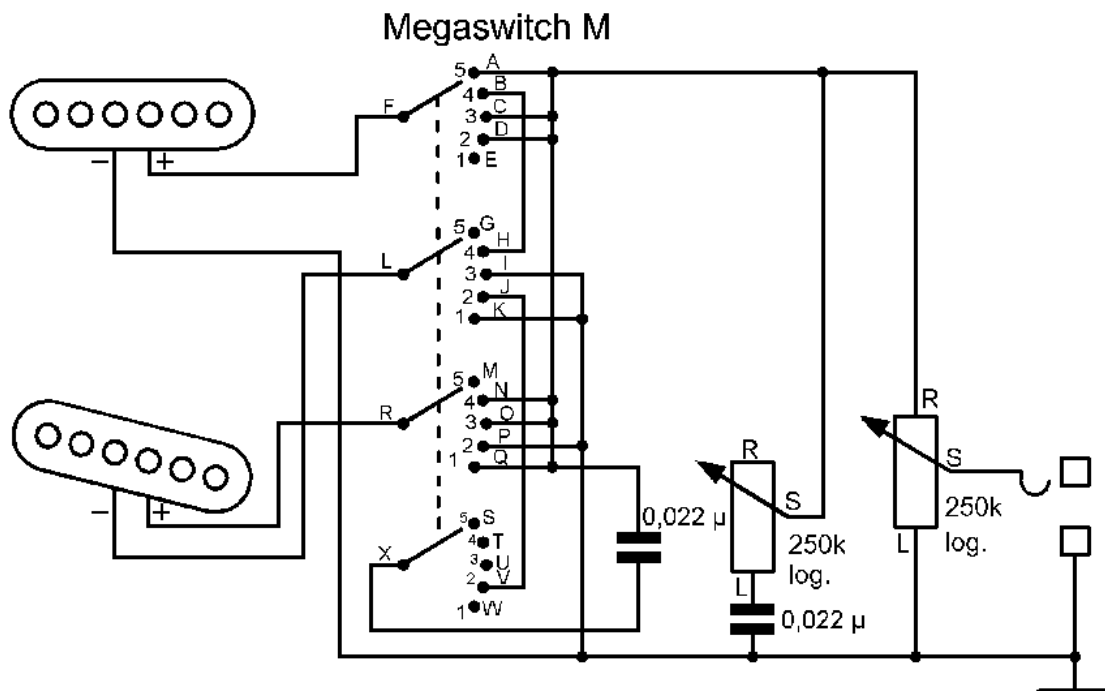
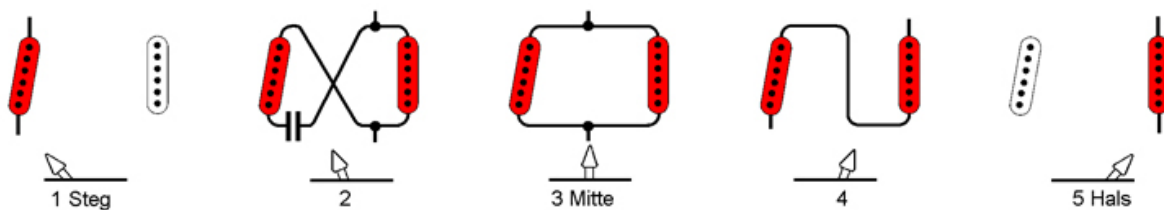

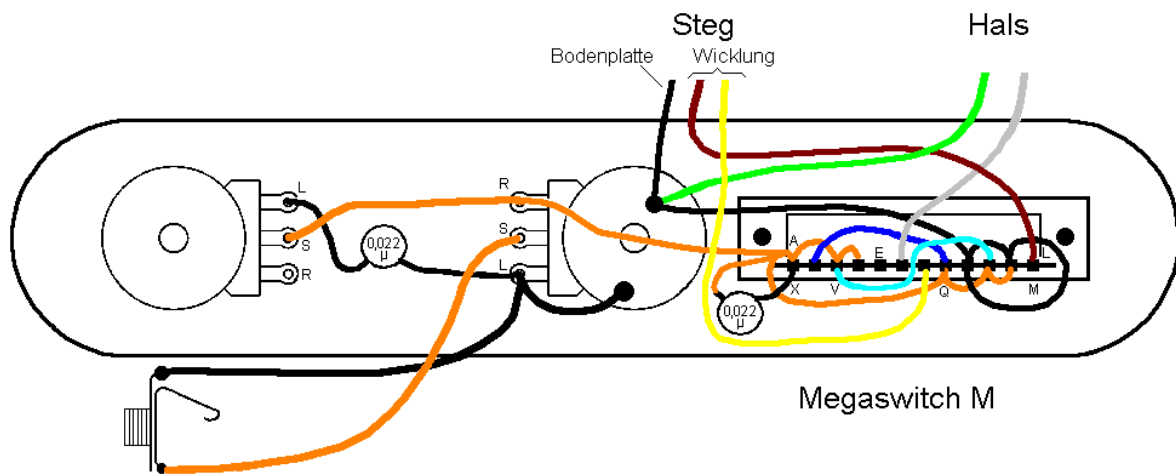

Connections:

Positions

- 1 bridge
- 2 bridge and neck out of phase parallel
- 3 bridge and neck in phase parallel
- 4 bridge and neck in phase in series
- 5 neck

Connections

- A to C, D, N, O, Q, capacitor, output
- B to H
- C to A, D, N, O, Q, capacitor, output
- D to A, C, N, O, Q, capacitor, output
- E -
- F neck hot wire
- G -
- H to B
- I to K, P, ground
- J to V
- K to I, P, ground
- L bridge cold wire
- M -
- N to A, C, D, O, Q, capacitor, output
- O to A, C, D, N, Q, capacitor, output
- P to I, K, ground
- Q to A, C, D, N, O, capacitor, output
- R bridge hot wire
- S -
- T -
- U -
- V to J
- W -
- X to capacitor (e. g. 0.022 μ F)
- ground: I, K, P and neck cold wire