

# Megaswitch E

You can use Megaswitch E for the following switching positions:

## SSS3

The combinations neck-plus-bridge and all-three-together cannot be obtained using a standard switching device. The neck-plus-bridge is extremely popular as it has a similar sound to a Telecaster. Some guitarists build an extra switch into their guitars to achieve this configuration. This is not necessary, however. It is much more easily obtained using the Megaswitch E. Positions 1, 2, 4 and 5, offer the usual sounds whereas in position 3, instead of the middle pickup, the neck-plus-bridge configuration is produced. When the magnetic orientation of the pickups is S-N-S or N-S-N, the positions 2 and 4 are buzz-free. If a buzz-free sound in position 3 is required, the neck and middle pickup can be exchanged which results in buzzing in position 2 however. It is also possible to create a buzz-free sound in position 3 by assigning the middle and the bridge pickup, which results in buzz in position 4.

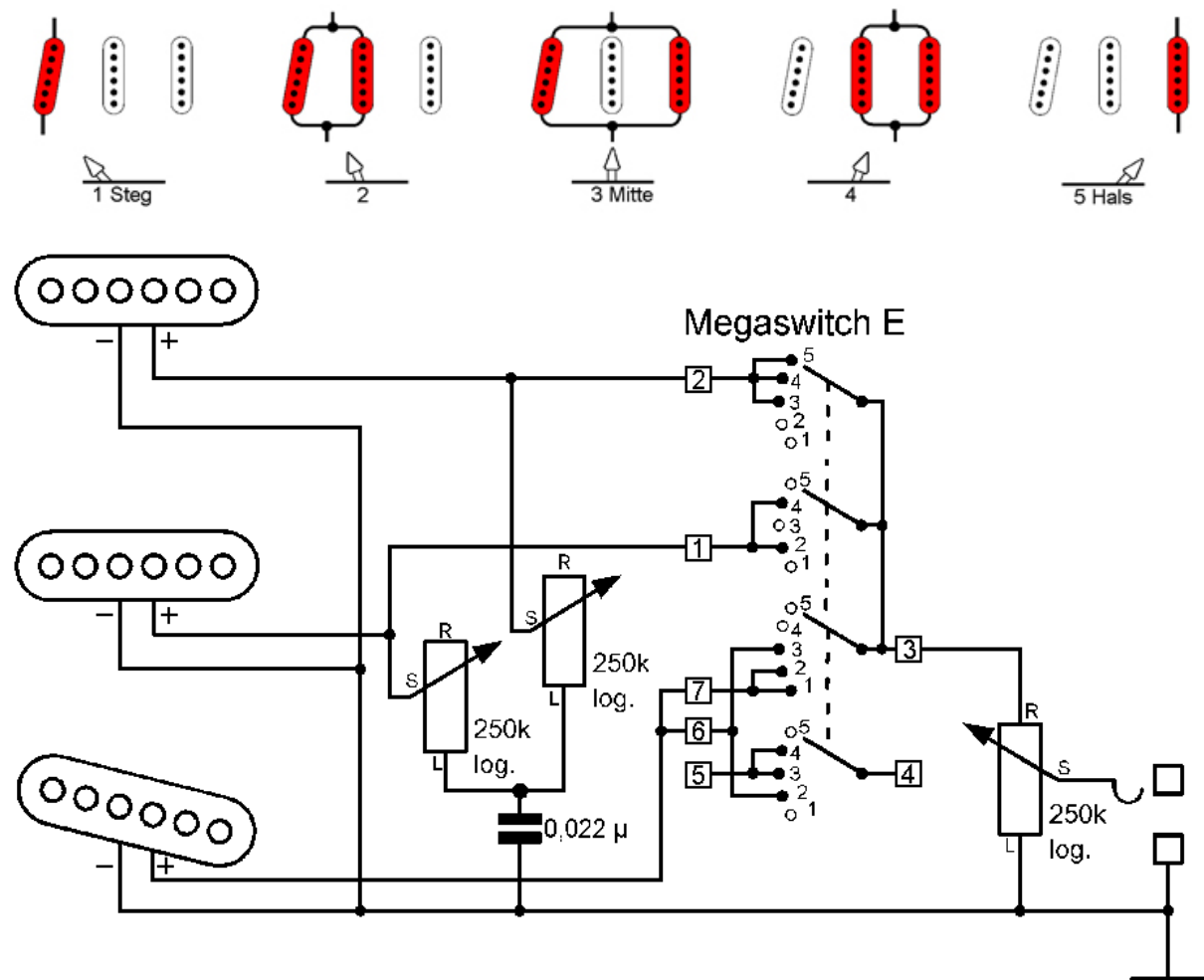

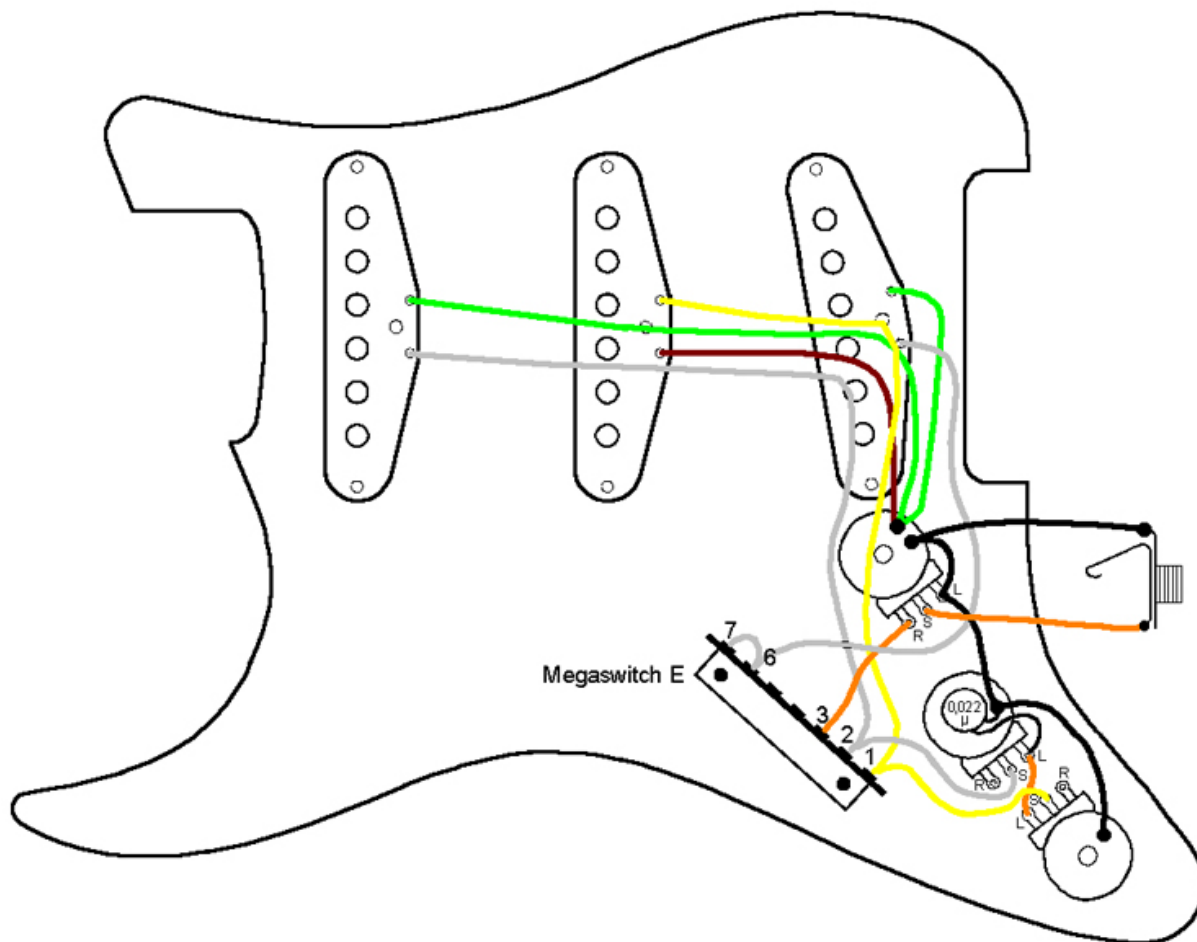

### Connections:

Positions

- 1 bridge
- 2 bridge and mid parallel
- 3 bridge and neck parallel
- 4 mid and neck parallel
- 5 neck

Connections

- 1 mid hot wire
- 2 neck hot wire
- 3 output
- 4 -
- 5 -
- 6 to 7, bridge hot wire
- 7 to 6, bridge hot wire
- ground: all three cold wires

## HSS4

With this switching system, the neck and the bridge pickups in position 3 are in operating mode, although the latter (the bridge pickup) is split. The inner coil remains in operating mode and the outer coil is open. In position 2 the Humbucker is split; the outer coil remains in operating mode and the inner coil is short-circuited. This enables a buzz-free sound in positions 1, 2, 3 and 4. The magnetic orientation of the coils (from the bridge to the neck) is required: NS-S-N or SN-N-S. Here, the Megaswitch E is used.

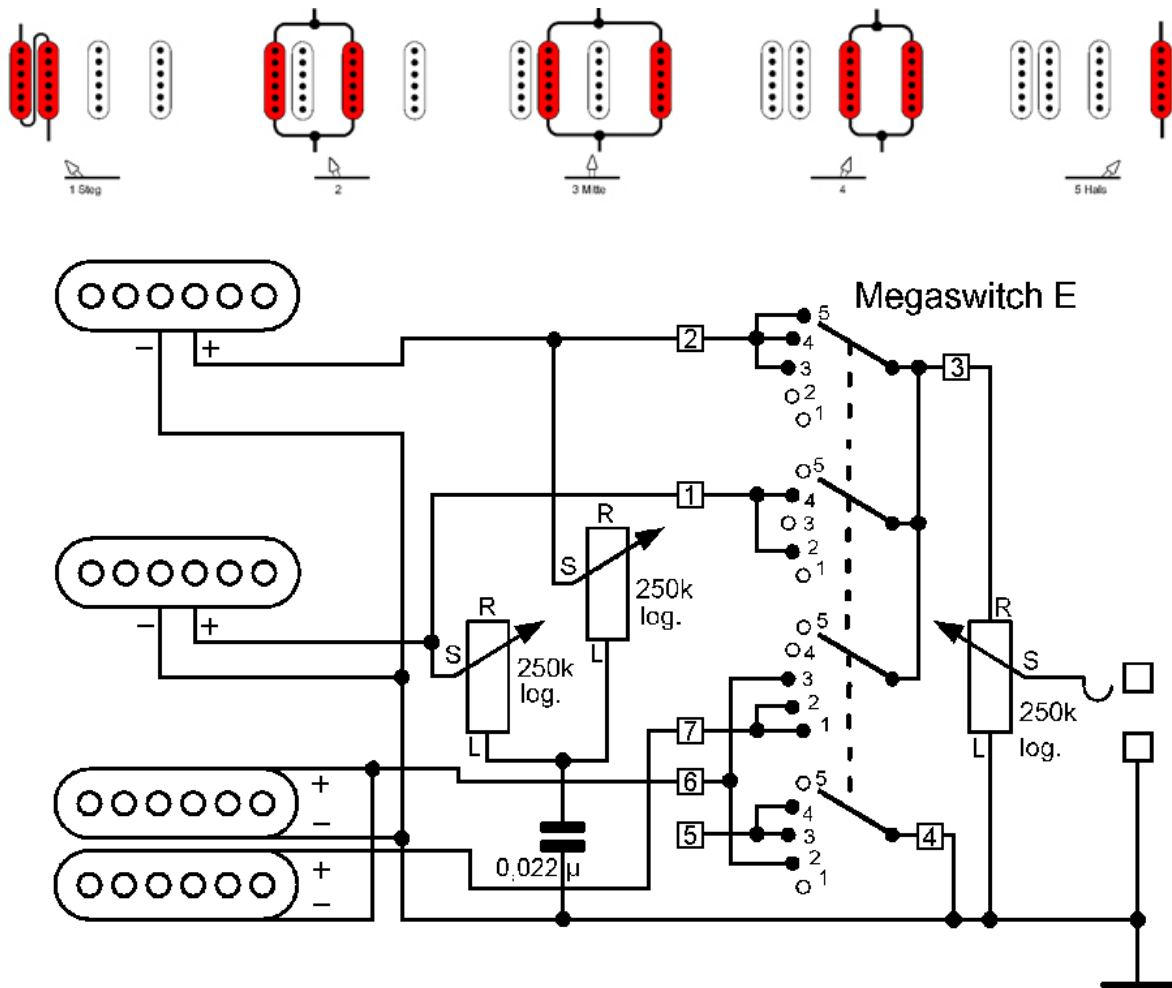

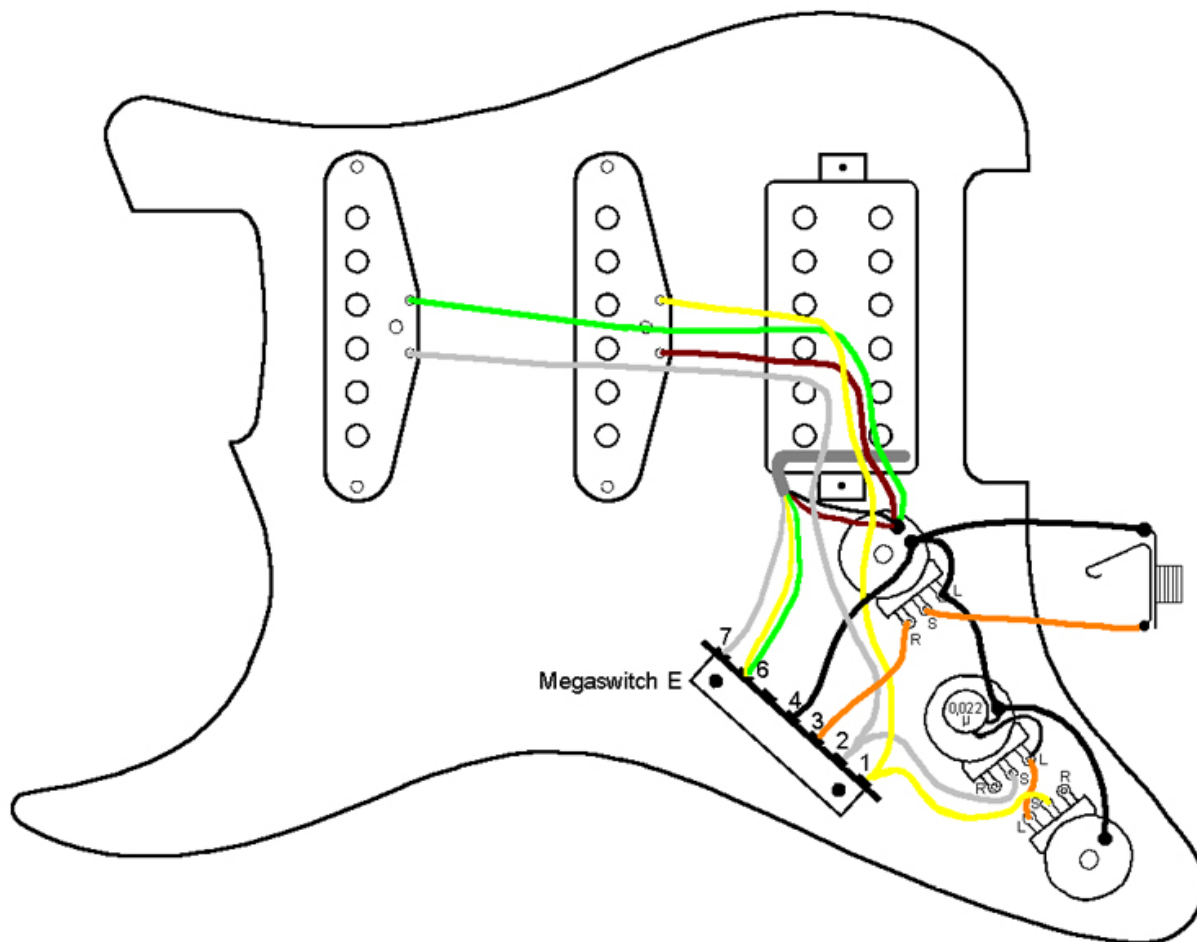

### Connections:

Positions

- 1 bridge humbucker
- 2 bridge outer coil and mid parallel
- 3 bridge inner coil and neck
- 4 mid and neck parallel
- 5 neck

Connections

- 1 mid hot wire
- 2 neck hot wire
- 3 output
- 4 ground
- 5 -
- 6 bridge hot wire inner coil and cold wire outer coil
- 7 bridge hot wire outer coil
- ground: 4, all three cold wires

## HSS5

This is a slight variation on the HSS4 switching system. In position 3 the neck and the bridge pickups are in operating mode, although the latter is split. The outer coil remains in operating mode and the inner coil is open. In position 2 the Humbucker is also split, although here, the inner coil remains in operating mode and the outer coil is short-circuited. This enables a buzz-free sound in positions 1, 2, 3 and 4. The magnetic orientation of the coils (from the bridge to the neck) is required: NS-N-S or SN-S-N. Here, the Megaswitch E is used.

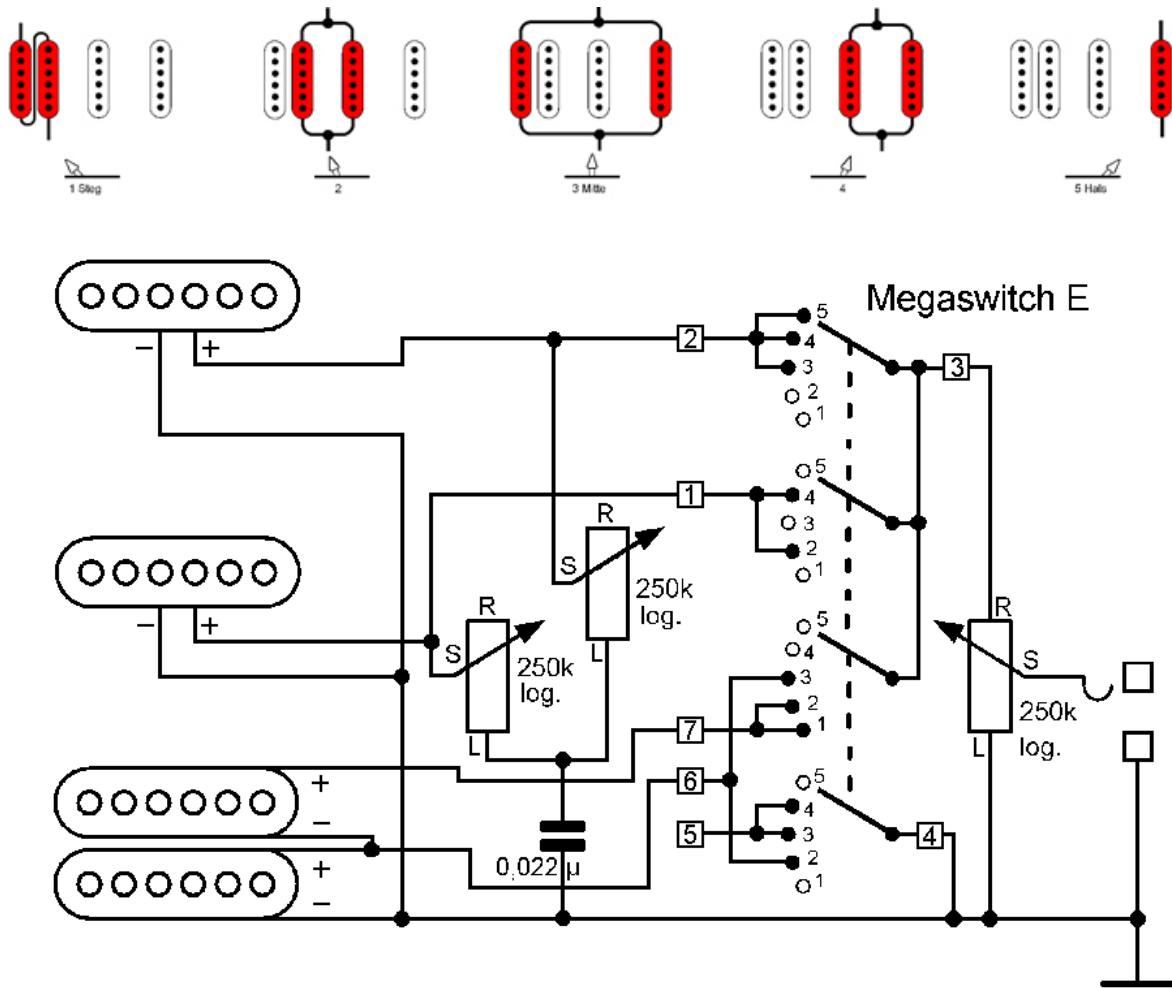

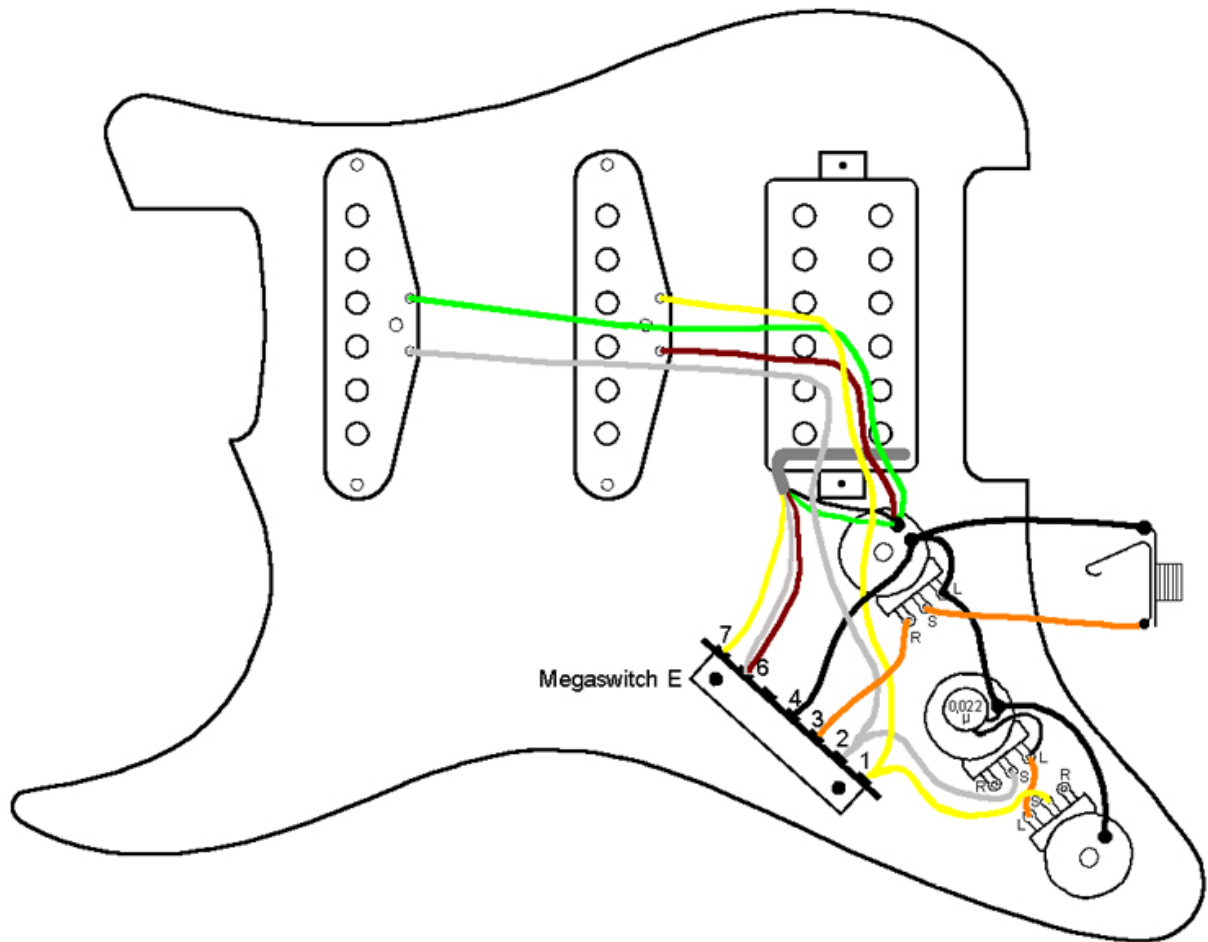

**Connections:**

Positions

- 1 bridge humbucker
- 2 bridge inner coil and mid parallel
- 3 bridge outer coil and neck
- 4 mid and neck parallel
- 5 neck

Connections

- 1 mid hot wire
- 2 neck hot wire
- 3 output
- 4 ground
- 5 -
- 6 bridge hot wire outer coil and cold wire inner coil
- 7 bridge hot wire inner coil
- ground: 4, bridge cold wire outer coil, mid and neck cold wires

## HH7

The HH7 is quite similar to the HH6, except that it features the Megaswitch E. Here too, by reversing the coil connections, a different coil can be made to remain active when the Humbucker is split. For a buzz-free sound, one north pole coil and one south pole coil must be in operating mode.

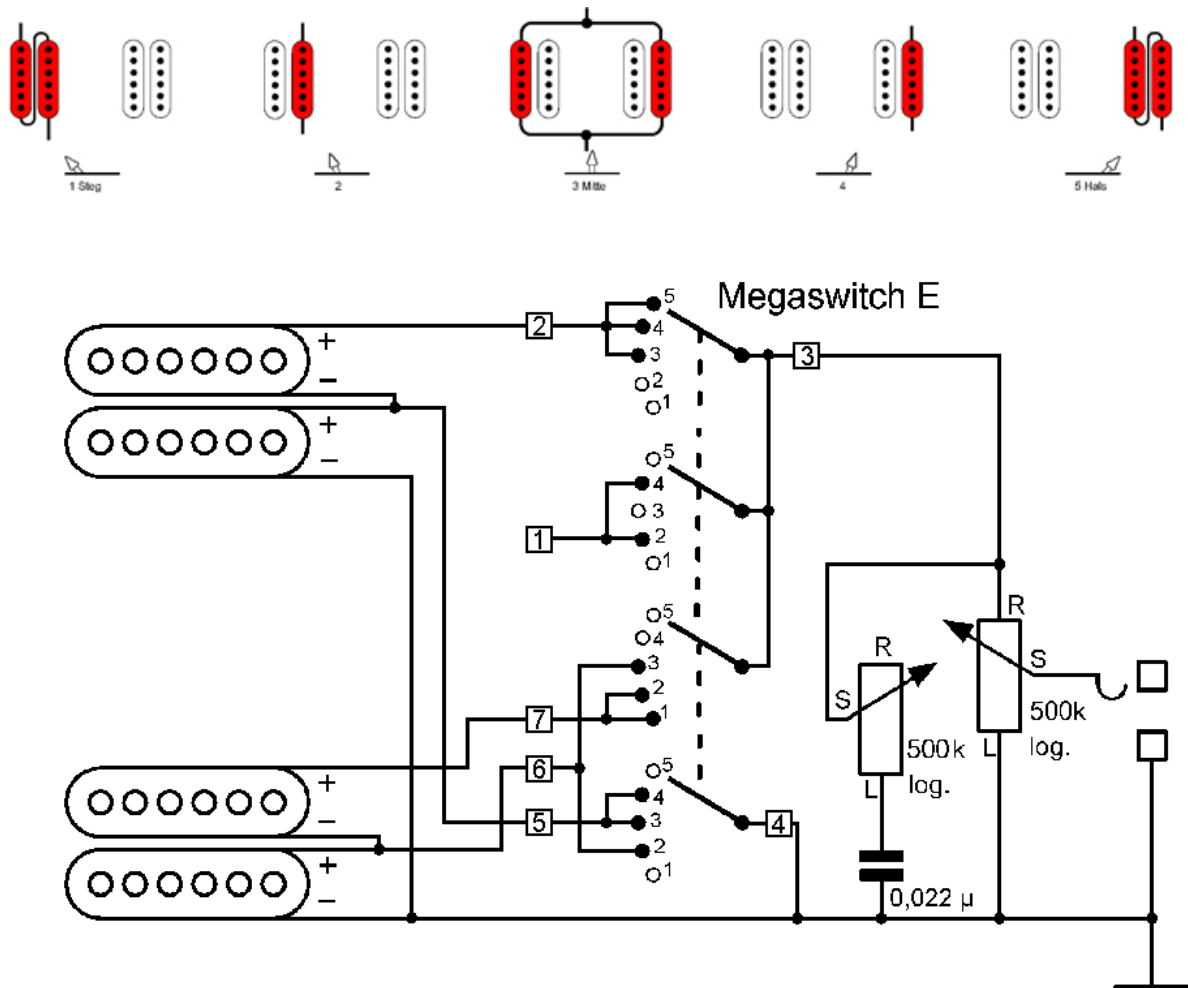

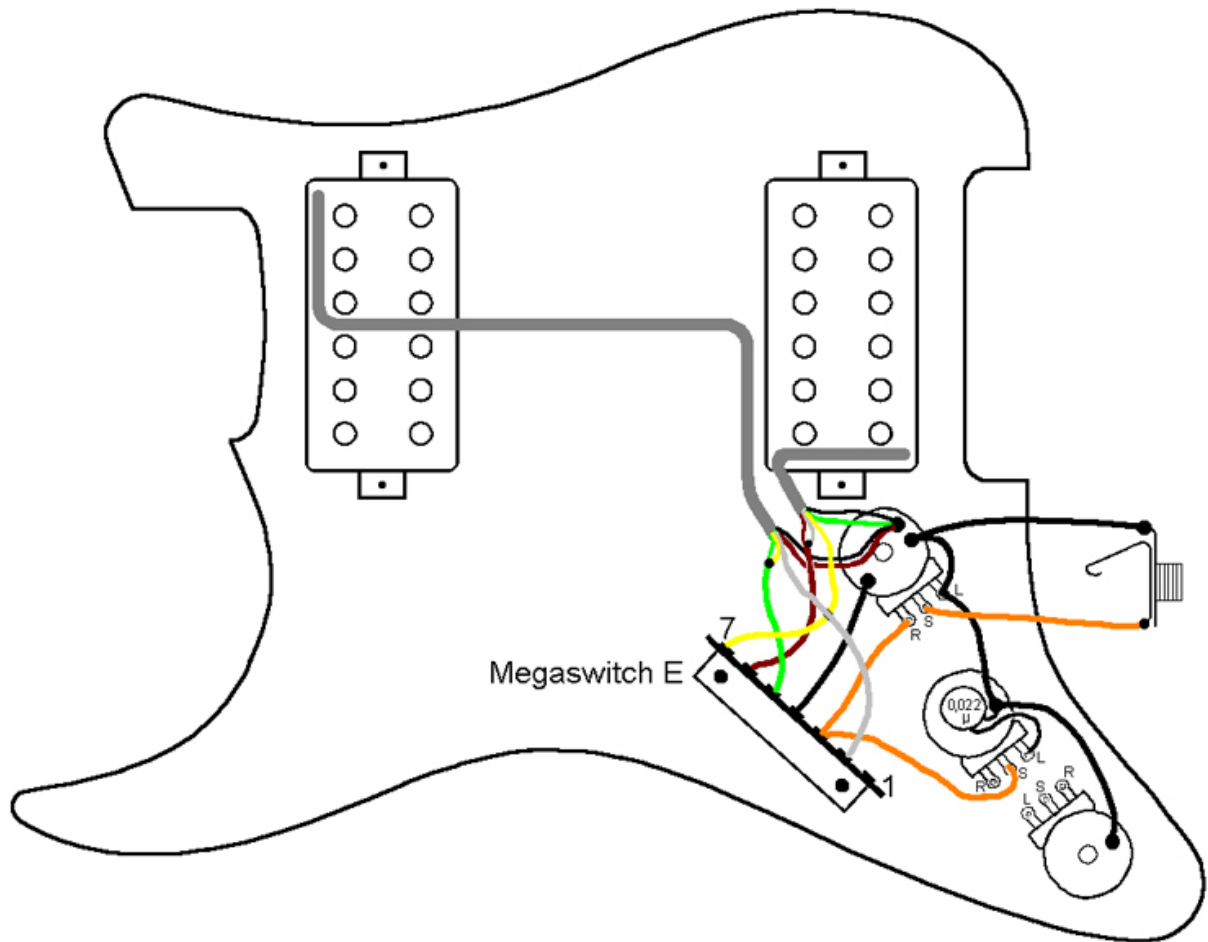

### Connections:

Positions

- 1 bridge humbucker
- 2 bridge inner coil
- 3 outer coils parallel
- 4 neck outer coil
- 5 neck humbucker

Connections

- 1 -
- 2 neck hot wire outer coil
- 3 output
- 4 ground
- 5 neck hot wire inner coil and cold wire outer coil
- 6 bridge hot wire outer coil and cold wire inner coil
- 7 bridge hot wire inner coil
- ground: 4, bridge cold wire outer coil, neck cold wire inner coil



## HSH4

This is a variation of the HSH3 switching system. The positions 1, 2, 4 and 5 are as usual and in position 3, the inner coil of the bridge Humbucker and the outer coil of the neck Humbucker are switched parallel. This results in sounds that are similar to a Telecaster, when both pickups are in operating mode. A buzz-free sound can be obtained in all positions; the following magnetic polarity is required - NS-S-SN or SN-N-NS. Here, Megaswitch E is in use. In this switching system, just a single tone control is advisable.

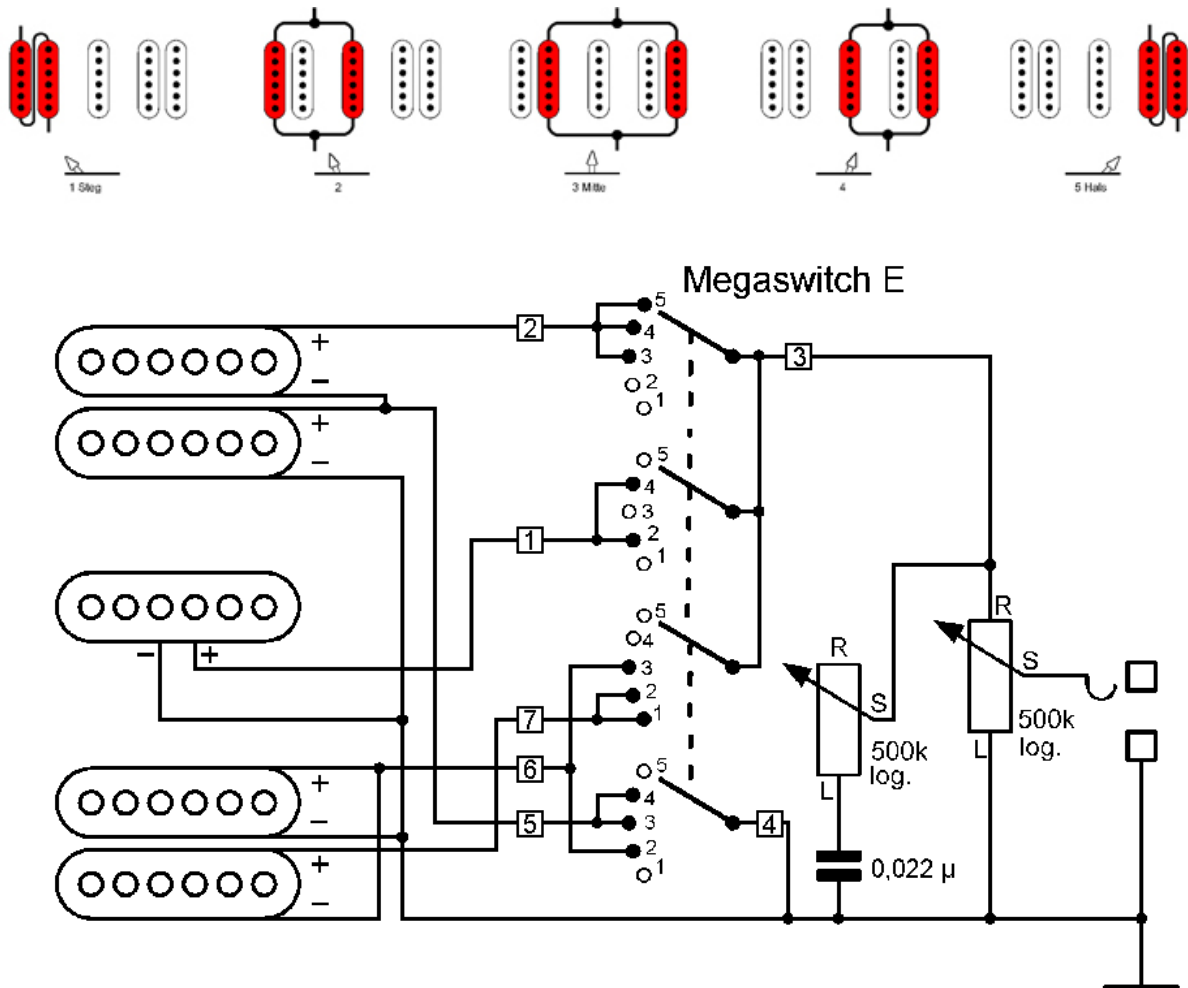

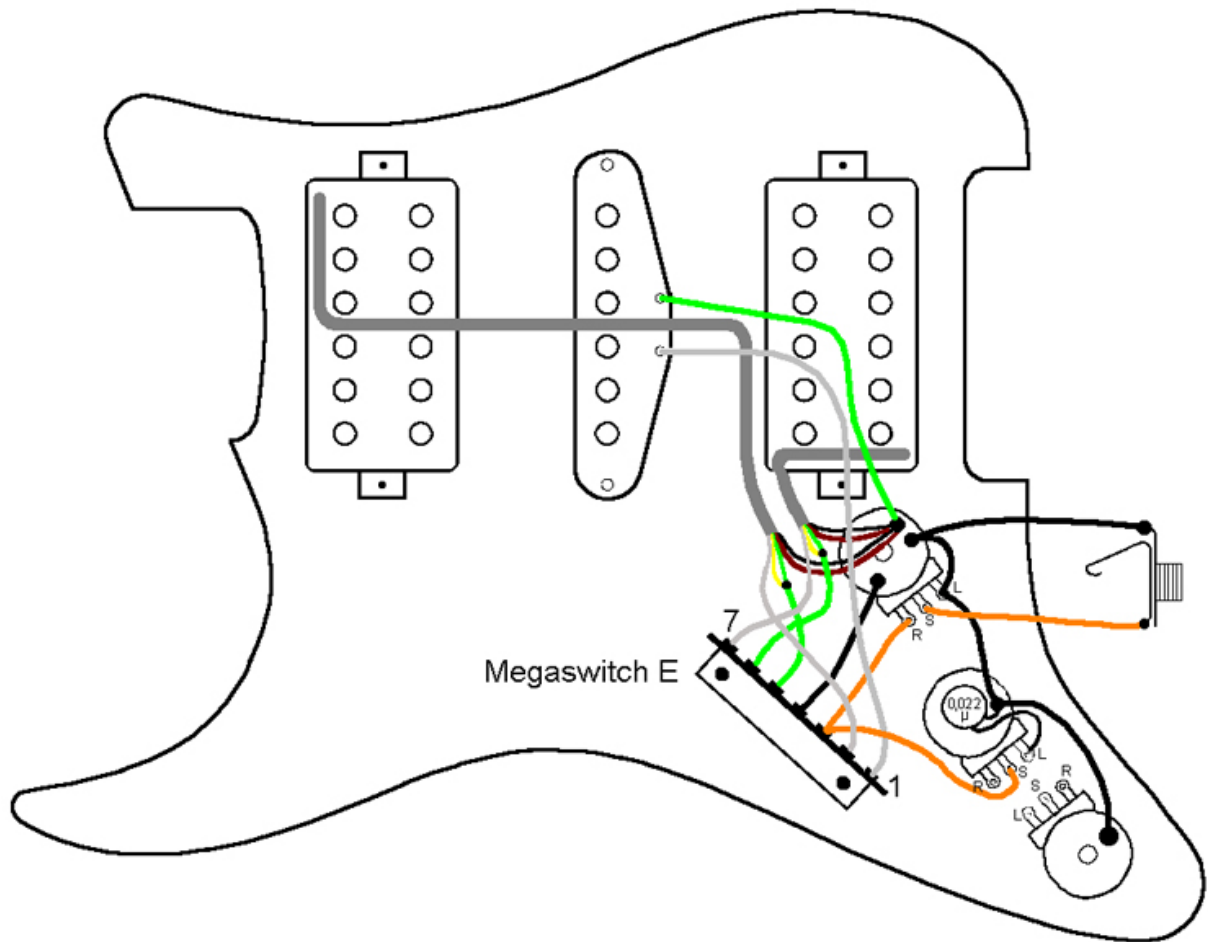

### Connections:

#### Positions

- 1 bridge humbucker
- 2 bridge outer coil and mid parallel
- 3 bridge inner coil and neck outer coil parallel
- 4 mid and neck outer coil parallel
- 5 neck humbucker

#### Connections

- 1 mid hot wire
- 2 neck hot wire outer coil
- 3 output
- 4 ground
- 5 neck hot wire inner coil and cold wire outer coil
- 6 bridge hot wire inner coil and cold wire outer coil
- 7 bridge hot wire outer coil
- ground: 4, mid cold wire and inner humbucker coils cold wires