

SS

SS: Two single coils

Overview

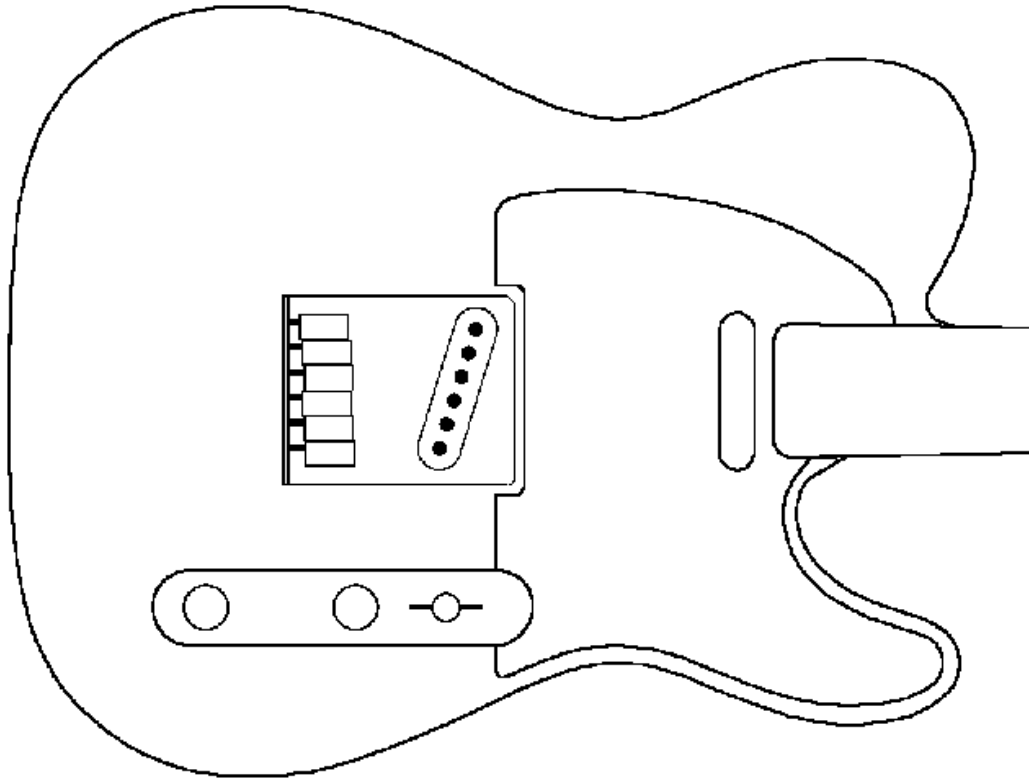

SS1. Standard switching, 3 positions, Megaswitch T

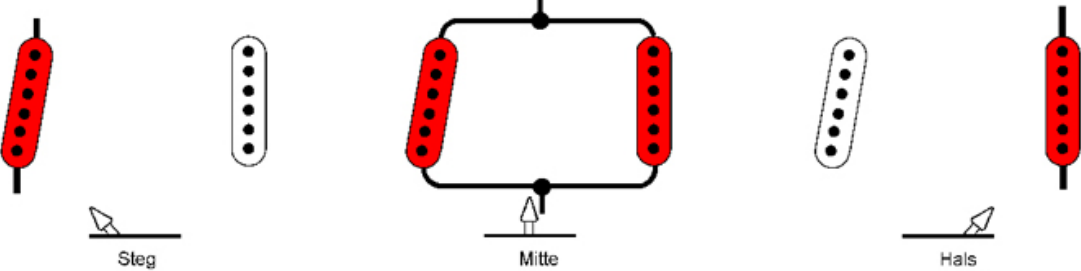

SS2. Three positions, in the middle position both in series, Megaswitch T

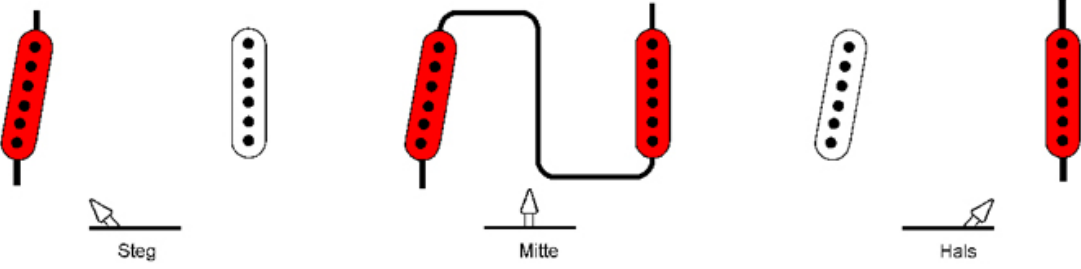

SS3. Five positions with series and reverse phase switching, Megaswitch M

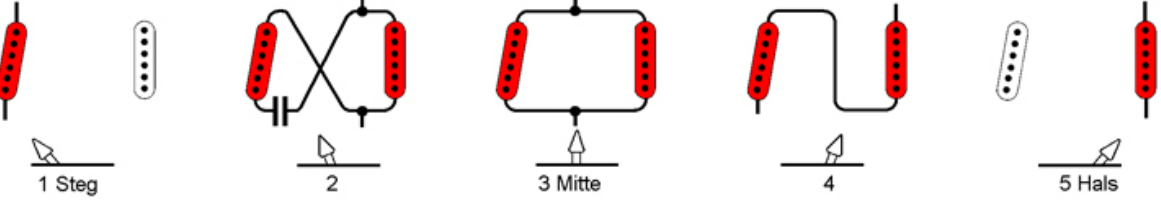

Detail drawing

SS1. Standard switching, 3 positions, Megaswitch T

This is the current switching system of the Telecaster since the 1960s. The switch has 3 positions and regulates the bridge pickup, either both parallel or with the neck pickup in operating mode.

If a buzz-free position is required in the middle position, the magnetic orientation must be as follows: N-S or S-N. The magnetic orientation must be N-S or S-N for no hum in the middle position. The Megaswitch T is ideal for this purpose.

Switching functions:

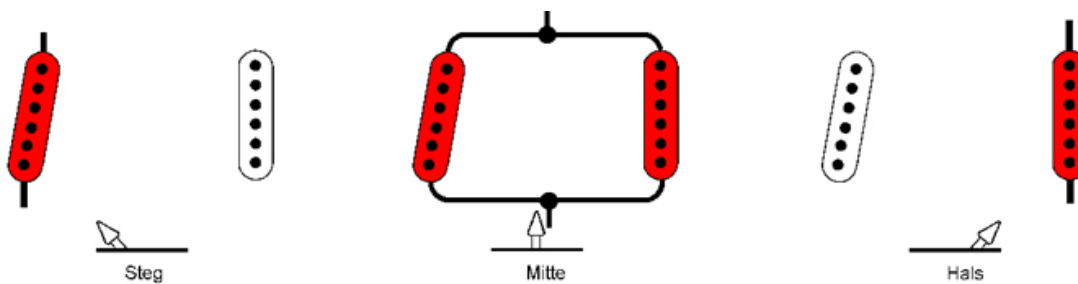

Electrical switching principle:

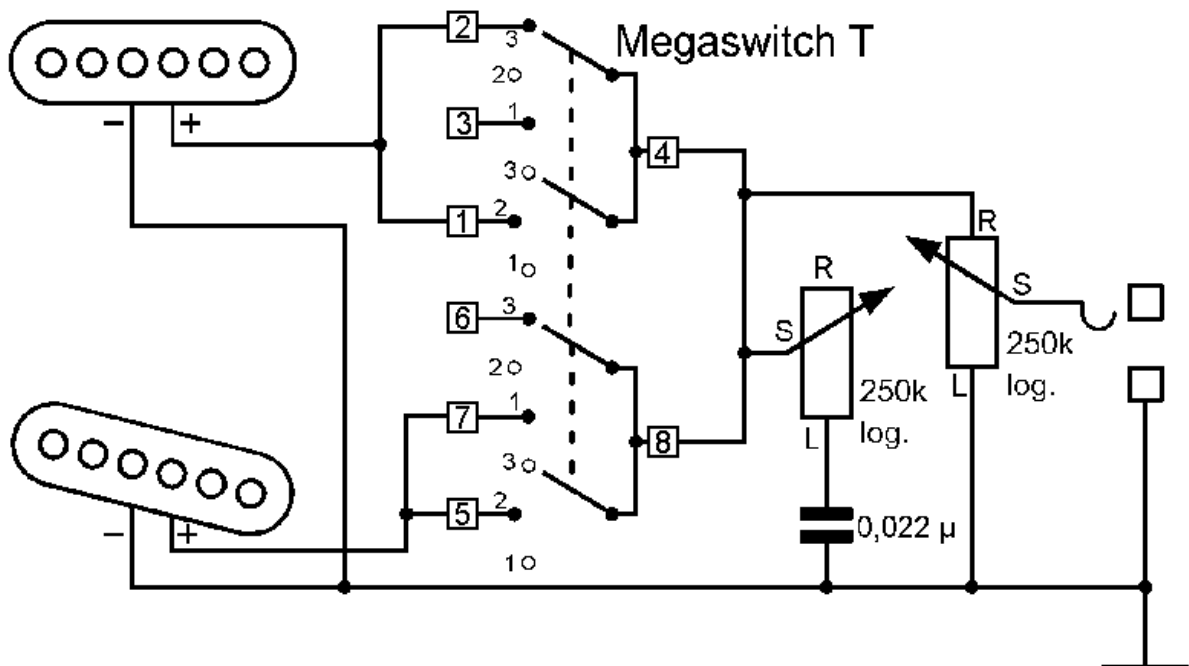

Wiring diagram:

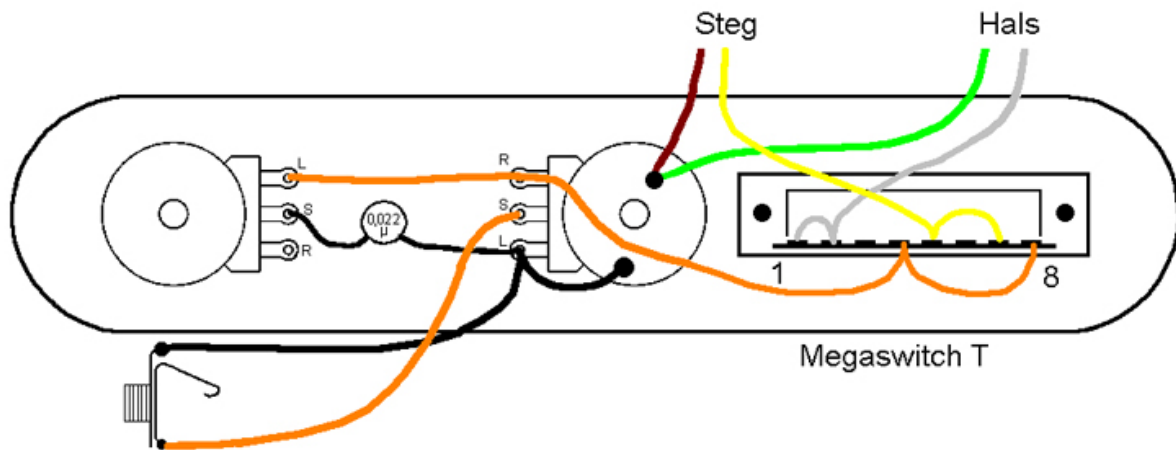

Connections:

Positions

1 bridge

2 bridge and neck parallel

3 neck

Connections

1 to 2, neck hot wire

2 to 1, neck hot wire

3 -

4 to 8, output

5 to 7, bridge hot wire

6 -

7 to 5, bridge hot wire

8 to 4, output

ground: neck and bridge cold wires

SS2. Three positions, in the middle position both in series, Megaswitch T

This is a version based on the Telecaster switching system. In the middle position both pickups are in series, which, compared to parallel switching, creates a fuller, louder tone. If a buzz-free sound is required in the middle position, the following magnetic polarity is required: N-S or S-N. The Megaswitch T is also ideal for this application. Warning: Here, the metal cap of the neck pickup must be electrically isolated from the coil and earthed/grounded via a separate wire. Some models are already equipped with 3 wires. See figure 3 in the introduction.

Switching functions:

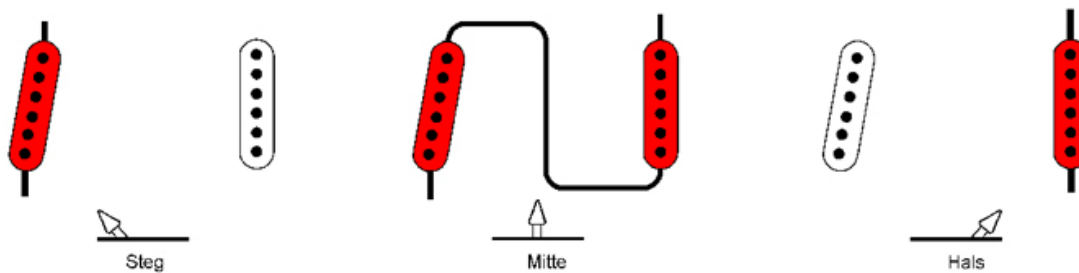

Electrical switching principle:

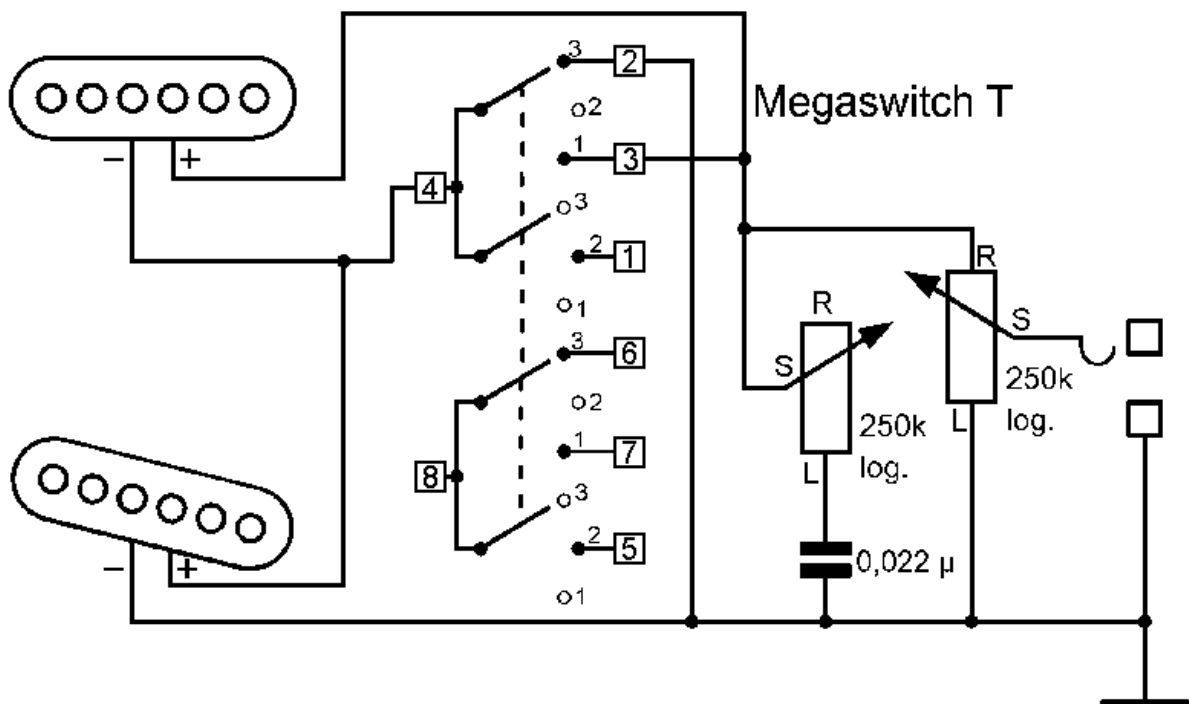

Wiring diagram:

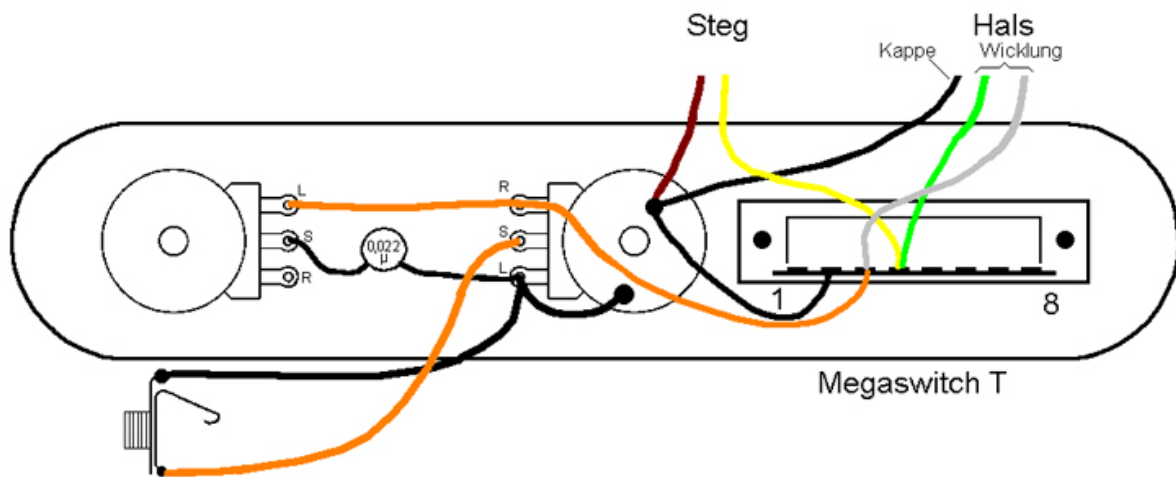

Connections:

Positions

1 bridge

2 bridge and neck in series

3 neck

Connections

1 -

2 ground

3 neck hot wire and output

4 neck cold wire and bridge hot wire

5 -

6 -

7 -

8 -

ground: 2, bridge cold wire

SS3. Five positions with series and reverse phase switching, Megaswitch M

This is a very versatile switching system for Telecaster-type guitars. The five-position switch produces the following combinations:

1. Bridge
2. Bridge and neck reverse phased and parallel
3. Bridge and neck phased and parallel
4. Bridge and neck phased and in series
5. Neck

Caution: Here, the base plate of the bridge pickup must be electrically isolated from the coil and earthed/grounded via a separate wire. The capacitor which is switched in series to the bridge pickup in position 2, improves the sound considerably by avoiding the weakening on the bass end of the sound spectrum usually associated with direct antiparallel mode. The value of $0.022 \mu\text{F}$ is a general guide only and can be increased or decreased as a matter of taste, depending on the resultant sound. The Megaswitch M is used here.

Switching functions:

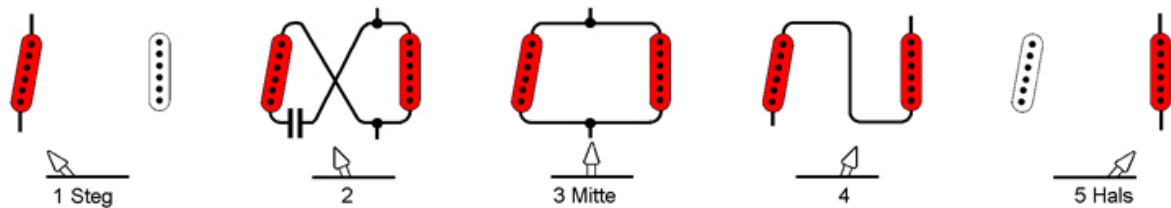

Electrical switching principle:

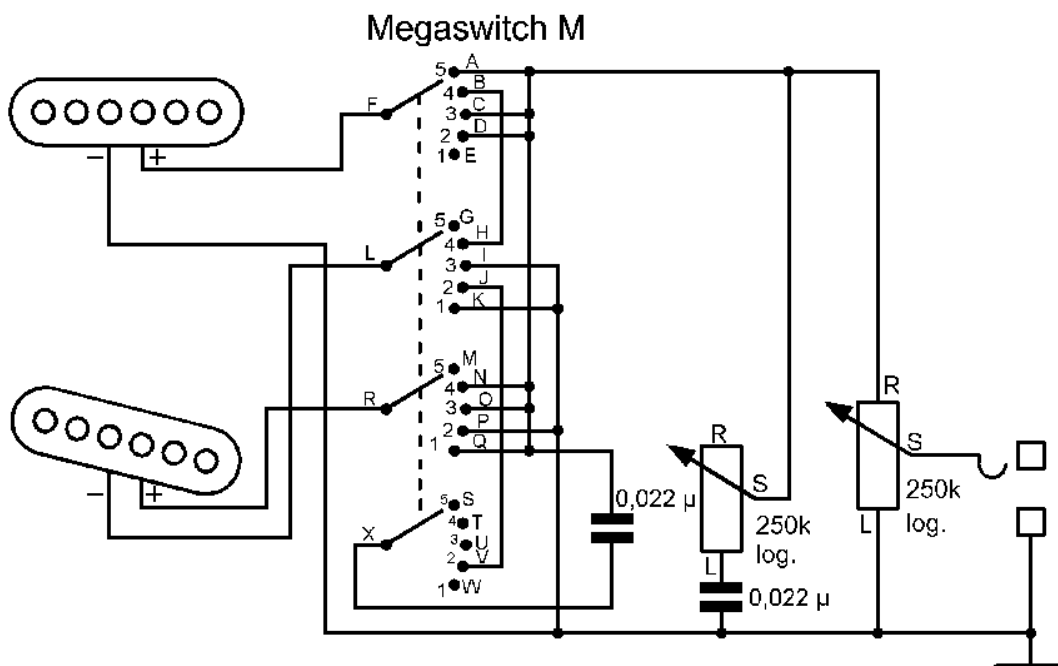

Wiring diagram:

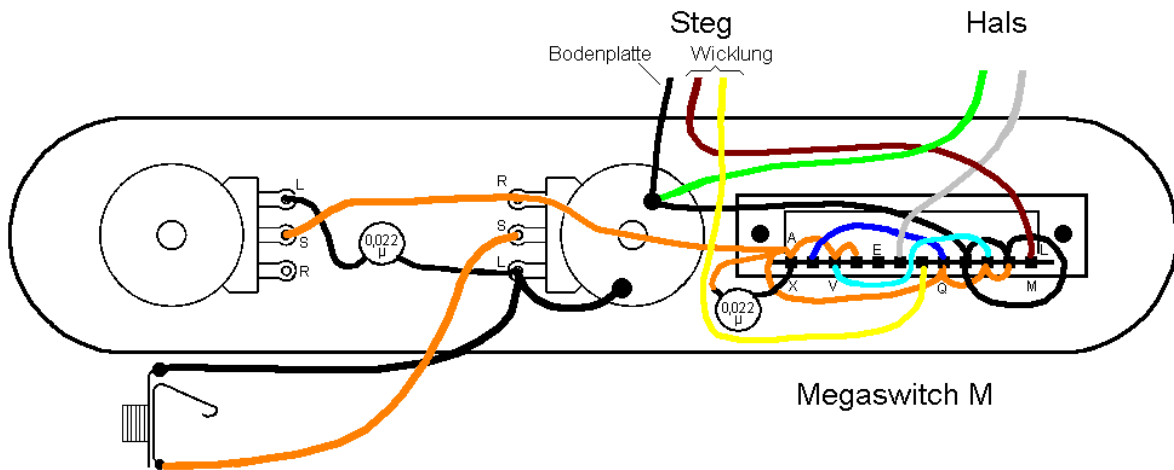

Connections:

Positions

- 1 bridge
- 2 bridge and neck out of phase parallel
- 3 bridge and neck in phase parallel
- 4 bridge and neck in phase in series
- 5 neck

Connections

- A to C, D, N, O, Q, capacitor, output
- B to H
- C to A, D, N, O, Q, capacitor, output
- D to A, C, N, O, Q, capacitor, output
- E -
- F neck hot wire
- G -
- H to B
- I to K, P, ground
- J to V
- K to I, P, ground
- L bridge cold wire
- M -
- N to A, C, D, O, Q, capacitor, output
- O to A, C, D, N, Q, capacitor, output
- P to I, K, ground
- Q to A, C, D, N, O, capacitor, output
- R bridge hot wire
- S -
- T -
- U -
- V to J
- W -
- X to capacitor (e. g. 0.022 μF)
- ground: I, K, P and neck cold wire